

Invasive Point Level System

Interface Gap Sensor

Description



The Ultrasonic Point Level System 167 Series is an ideal solution for detecting the interface level of two non-homogenous liquids, or the interface level of solids suspended in liquid. The probe is constructed in 316LSS material. The electronic module is captured in a plastic cassette and is mounted in a NEMA 4/7 explosion proof housing. An LED indicator on the electronic module offers a visual status of the system. Field selectable Fail safe allows for the relays to be energized on power up or in normal condition to de-energized when liquid is present. A Demand Push button self-test feature on the electronic module assures the user the system is functioning correctly.

Operation

The 167 Series unit consists of two piezoelectric elements mounted in the housing of the sensor. These elements convert mechanical energy in the form of high frequency sound to electrical energy and vice versa. The elements are mounted parallel and opposite each other across the gap in the probe. A high frequency sent from the electronics to the transmitting element, this vibrates the element at 2 to 4 MHz. Neither Air or gases will carry sound at this high frequency and will not travel across the sensor gap. When the gap is filled with liquid, the sound will travel across the gap to vibrate the receiving element. The vibration generates an electrical signal that is amplified and read by the detector circuit in the electronics as a "wet" signal. The signal is converted to a relay output or a shift in milliamp output

How to Order	HT167-	-	-	-	-	-	-	-	-	-	-	-	-	-	-	-	-	-	-
Input:	24VDC	0																	
	90 to 240VAC	1																	
	9-30VDC	2																	
Output:	10 ADPDT	--	0																
	Loop Power (4-20mA)	--	1																
Mounting:	Integral	--	--	1															
	Remote	--	--	2															
Cable (remote):	in feet	--	--	--	01														
Actuation point inches	(01"std)	--	--	--	--	01													
	Gap (6" std)	--	--	--	--	--	6												
Process connection	3/4"NPT	--	--	--	--	--	--	03											
	Flange ANSI 150#	--	--	--	--	--	--	--	A										
	Flange ANSI 300#	--	--	--	--	--	--	--	B										
	Flange Sanitary	--	--	--	--	--	--	--	C										
	Flange size 1"	--	--	--	--	--	--	--	1										
	1.5"	--	--	--	--	--	--	--	0										
	2"	--	--	--	--	--	--	--	2										
	Sensor Material	--	--	--	--	--	--	--		S									

Applications	Industries served
High Level / Overflow Alarm	Upstream Oil & Gas
Low Level / Pump Protection	Midstream Oil & Gas
Condensate Pots	Water & Waste- Water
Sump Water / Oil Detection	Chemical & Petrochemical
Lubricant Circulation Equipment	Pulp & Paper
Fill Machine Level Control	Food & Beverage
Pump Leak Detection	Military, Subsea / Surface
	Maritime Shipping
	Inland Barges, ERC Cargo

Sensor material 316LSS is standard, other materials available
 Other flange and pressure ratings available
 Other remote mounted enclosures available
CONSULT FACTORY FOR CUSTOMIZATION

SENSOR DIMENSIONS

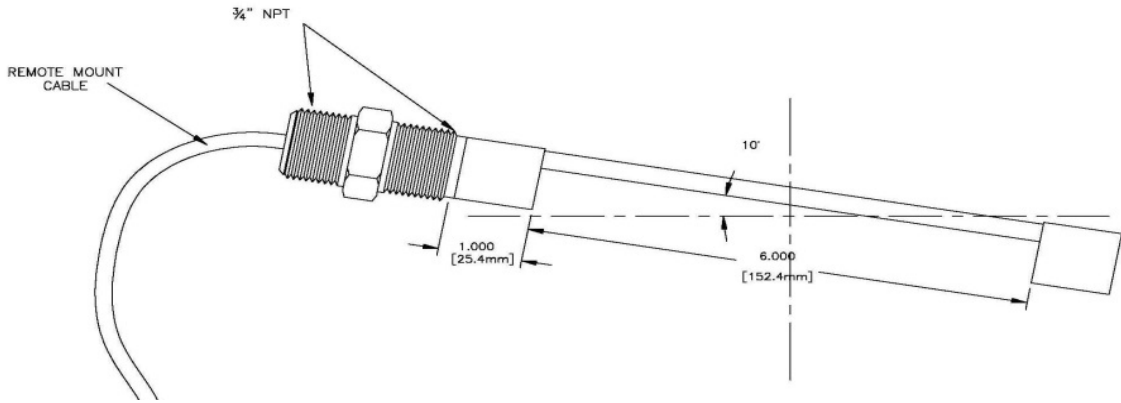

- Repeatability: 2mm or better.
- Delay (on): 0.5 seconds Standard.
- Probe material: 316SS Standard.
- Optional material available.
- Actuation point: 1.0" Standard.
- Up to 99" available.
- Sensor Temperature: -20° to 150°C
- Sensor Pressure: 1000 PSIG 316LSS.
- Liquid viscosity : From 1 to 75,000 cps
- Process connection: 3/4" NPT Standard
- Flanges mounting available.
- Input options: 24VDC, 90 to 240VAC,
- Output Options: 10A DPDT
- Push Button Demand Self-Test
- Field Select Fail-Safe Option
- LED Output Indicator
- Electronic mounting : Integral or Remote
- Enclosure: Nema 4 / 7

ELECTRONIC MODULE ENCLOSURE DIMENSIONS

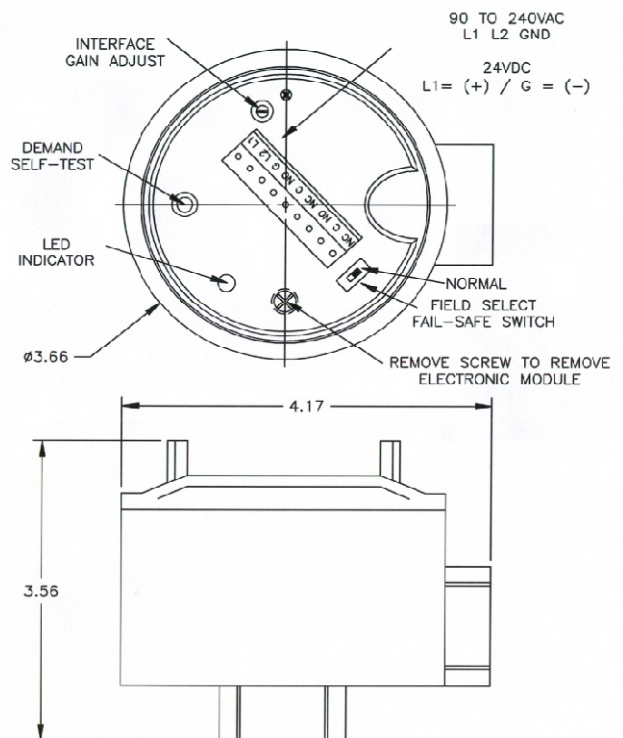

Warranty

HiTECH' level sensors are warranted against inherent defects for a period of two years from the date of shipment.

Performance Guarantee

Should the unit not perform as we claim within 45 days of delivery and was properly installed consistent with our stated requirements and specifications HiTECH will gladly accept a return of the unit for a full credit.

CSA Approval (pending) Explosion Proof
Class I Group CD
Class II Group EFG
Class III Type 4. EP. IP 65.

Disclaimer: Due to technical progress all Data Sheets are subject to change without notice. HiTECH believes all information in this Data Sheet is correct but is not responsible for any inaccuracies. HiTECH is not liable for any damages. It is the customer's responsibility to install, operate and maintain products properly.