



MICROWAVE SOLIDS FLOW SENSOR

MWS-DP-3

With high penetrability of buildup material on the sensing head, this sensor can detect moving material such as powders, granules, etc. by utilizing the Doppler effect.

Equipped with a sensitivity margin indicator and a filter for screening unnecessary incoming Doppler signals



WADECO CO.,LTD.

MICROWAVE SOLIDS FLOW SENSOR MWS-DP-3

General

The MWS-DP-3 Microwave Solids Flow Sensor detects moving solids utilizing microwave high penetrability and the Doppler effect. The sensing head transmits microwaves toward the target material. A portion of the microwaves are reflected back to the sensing head and analysed as to whether they are from a moving or stationary object. The highly-penetrable microwave passes through a buildup on the head and even through pipe made of non-conducting materials such as plastics. It is best suited for detecting such materials as powders, granules, etc, moving through a vacuum pipeline.



Penetrability / Doppler effect of microwaves

When microwaves transmitted through the air encounter an object, some will be reflected, some absorbed and the rest will pass through the object.

The amount of microwaves that pass through the object depends on the composition of the object encountered.

Generally speaking, microwaves cannot penetrate metals and are reflected; water absorbs the most microwaves.

Microwaves can easily pass through plastics, glass, ceramic, paper etc.

On the other hand, when microwaves are transmitted and reflected back to the sensor from a moving object, a frequency shift is generated between the transmitted and the reflected waves by means of the Doppler Principles, which is converted to a motion signal and actuated an output relay.

Wiring

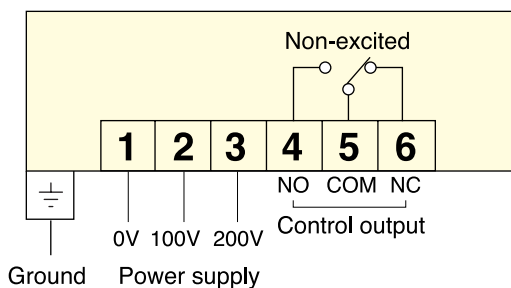

Selection of mode and relay configuration

Detection mode		Flow		Non-flow	
Terminal number		4-5	5-6	4-5	5-6
Unpowered state		Open	Close	Open	Close
Powered state	Non-detecting state	Open	Close	Open	Close
	Detecting state	Close	Open	Close	Open

Features

- **High penetration**

Easily penetrates process buildup on antenna, firebrick, refractory etc.,

The sensor can be installed on the exterior of a plastic or ceramic pipe and detect the flow of the material in the pipe.

- **Non-intrusive installation**

Mounted flush, no intrusion or damage to material flow.

- **Equipped with a filter for screening unnecessary incoming Doppler signals**

This function eliminates unnecessary incoming Doppler signals such as, signals from a vibrating pipe or conveyer and improves the S/N ratio.

This enables the sensor to be used in places where previously, non-contact flow detection was hardly possible.

- **Equipped with a sensitivity margin indicator**

The received power level and the sensitivity set point are indicated on the sensor allowing for easy visual adjustment and maintenance of the sensor.

The indicator clearly displays the advantage of the filter screening effect.

- **Selectable detection mode**

Either flow or Non-flow detection mode may be selected.

- **Equipped with a test button**

LED indicators indicate microwave circuit status and internal temperature when the test button is pushed.

- **Equipped with a Doppler signal incoming indicator**

An LED indicator turns on when the Doppler signal is received. Flow and non-flow conditions are clearly displayed.

Function of Switches, Indicators and Rheostats

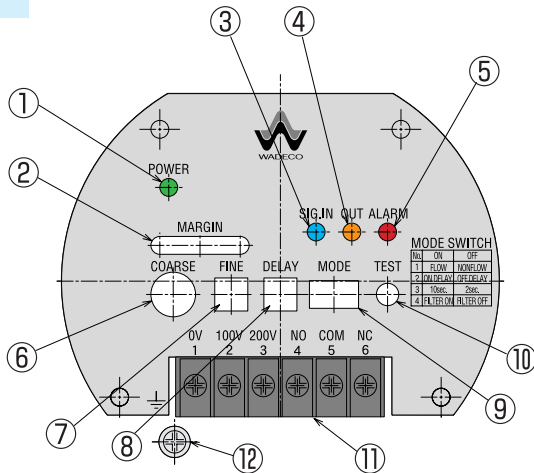

No.	Part Name	Description
1	Power indicator	Green when power is on
2	Sensitivity margin indicator	Indicates sensitivity margin for nonflow and flow conditions
3	Signal incoming indicator	Blue when doppler signal is received
4	Output indicator	Orange when flow or non-flow is detected
5	Alarm indicator	Red when alarm is output
6	Coarse sensitivity rheostat	For sensitivity adjustment
7	Fine sensitivity rheostat	For fine sensitivity adjustment
8	Delay time rheostat	Delay time to detection output
9	Mode switch	Selects detection mode Factory adjustment 1:ON 2:OFF 3:ON 4:OFF
10	Test button	Transmission halt, signal incoming condition and temperature are indicated when the test button is pushed.
11	Terminals	
12	Earth terminal	

Sensitivity adjustment

After finishing the installation and wiring, check the following and adjust the sensitivity.

- Upon turning on the power supply, the power light ① POWER (Green) will turn on.
- Turn the delay time rheostat ⑧ counter-clockwise to set it at the minimum point.
- Turn the coarse sensitivity rheostat ⑥ fully clockwise to set it at-maximum. Next, turn the fine sensitivity rheostat ⑦ fully counter-clockwise to set it at minimum.
- Confirm the output indicator ④ OUT (orange) is off while operating the pipeline with an empty condition. If the output indicator ④ OUT (orange) is on, turn the coarse sensitivity rheostat ⑥ counter clockwise slowly and find the point where the output indicator ④ OUT (orange) turns off. This is the actuating point for the non-flow condition.
- While operating the pipeline with a continuous flow to be detected, you can see the output indicator ④ OUT (orange) turn on. Turn the coarse sensitivity rheostat ⑥ further counter clock wise slowly and find the point where the output indicator ④ OUT (orange) turns off. This is the actuating point for the flow condition.
- Set the coarse sensitivity rheostat midway between the actuating point for the non-flow condition and the actuating point for the flow condition. This is the sensitivity set point. The margins from the flow and non-flow actuating points to the sensitivity set point can easily be seen by viewing the sensitivity margin indicator ②. Vibration and surrounding noise from other machinery such as conveyers etc, will sometimes increase receiving power levels in the non-flow condition and result in unwanted detection. You can use the filter function to increase the margins and avoid any unwanted detection by turning on the mode switch No.4 ⑨ and repeating adjustment procedures (steps 4 to 6).
- In order to detect a sporadic flow, set the continuous detecting limit with the delay time rheostat ⑧
- In order not to detect a sporadic flow, set the non-detecting limit with the delay time rheostat ⑧ after turning on the mode switch No.2 ⑨.

Specifications

Type	MWS-DP-3
Detecting method	Utilizes the Doppler Principle for detecting moving material
Power supply	AC100 ~ 120V or AC200 ~ 240V ±10%, 50/60Hz
Power consumption	2W
Operating distance	Up to 1.5m (Depending on material)
Frequency/Transmitting power	Approx. 24GHz, less than 10mW
Sensitivity margin indicator	Displayed by 7 LEDs
Control output	1C relay contact AC250V, 2A(cosφ=1)
Delay function	ON/OFF delay (Selectable), 0 ~ 10sec. / 0 ~ 2sec. (Selectable)
Delay time from power on to function	Approx. 8 seconds
Doppler signal incoming indicator	Blue LED
Mode selection	NO.1:Flow/Non-flow detection NO.2:On/Off delay NO.3:Delay time, 10SEC./2SEC. NO.4:Filter, On/Off
Test function	Microwave circuit status and sensor's temperature are indicated by LED when the test button is pushed.
Noise tolerance	Pulse noise from noise simulator ±1.5kV (normal and common mode)
Vibration resistance	10 ~ 55Hz, 0.75mm single amplitude in X, Y and Z directions, for 2 hours each
Operating ambient temperature	-20°C to +55°C
Non-functioning temperature	-30°C ~ +70°C
Continuous maximum pressure	0.5MPa
Enclosure rating	IP65 equivalent
Enclosure construction	Diecast aluminium
Color	Metallic silver grey
Weight	1.2kg

Installation

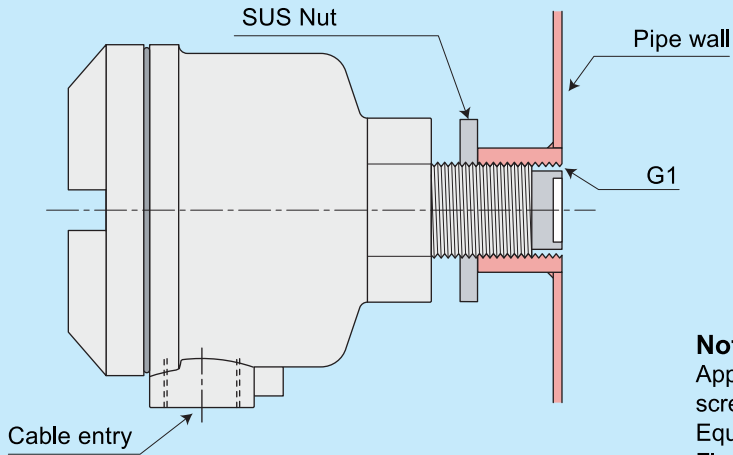

Notes:

Apply liquid sealant into screw hole and/or any gaps.
Equipped with an SUS nut.
Flange mounting is also available.

Dimensions

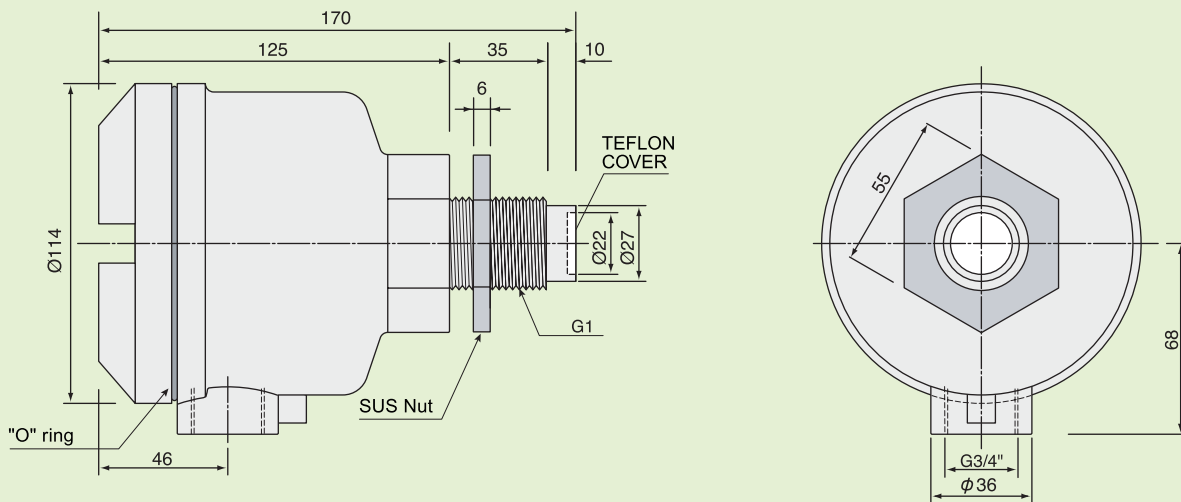

This specification may be changed without notifying the buyer.



WADECO CO.,LTD.

HEAD OFFICE 1-9-27, Jokoji, Amagasaki-shi, Hyogo-ken 660-0811, Japan
TEL. +81-6-6482-3838 FAX. +81-6-6481-6321

TOKYO BRANCH 202 Shibuya-homes, 2-1, Udagawa-cho, Shibuya-ku, Tokyo
150-0042, Japan
TEL. +81-3-3770-5519 FAX. +81-3-3770-5520
URL : <http://www.wadeco.co.jp>