

MANUAL

"HYGIENIC" LEVELSWITCH Type "KMW"



ATTENTION!

With connection G
(1/2" BSP)
Max. torque 10 Nm



Features:

- Hygienic Level switch for liquids
- Adjustable sensitivity
- 7 base settings for different media (different viscosity from fluid)
- Further settings via PC and programming interface (extra price)
- Wetted parts SS 316 and PEEK
- EHEDG certified
- Compact design
- CIP / SIP cleanable (max. 150°C)
- No O-ring used

Technical features:

Wetted parts	: Stainless Steel 316 and PEEK
Electronics housing	: Stainless Steel 304
Electrical connection	: PG 9 or M12 plug
Process connection	: 1/2" BSP male or 1" BSP male
Power supply	: 18...32 Vdc
Output signal	: PNP (NC/NO)
Response time	: < 0,2s
Ambient temperature	: -10...+60°C
Process temperature	: 0...+150°C
Storage temperature	: -20...+70°C
Protection grade	: IP67
Indication (internal)	: LED

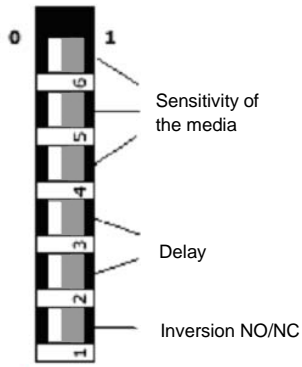

As standard dipswitch = 0-0-0-0-0-0
Applicable for almost every fluid

Switch			Turn on/off values in %		Delay switch		
6	5	4	On	Off	3	2	
0	0	0	86	84			Delay in sec.
0	0	1	97	96			
0	1	0	72	70	0	0	0sec
0	1	1	60	58	0	1	2sec
1	0	0	50	48	1	0	4sec
1	0	1	11	9	1	1	8sec
1	1	0	5	4			
1	1	1	Configuration via PC				

Typical applications are:

The KMW is a micro-processor based limit switch for liquids, paste-like and adhesive medias.

- High / low level detection in tanks
- Media registration in pipes as pump protection
- Fill level protection of liquids in tanks, containers or pipes

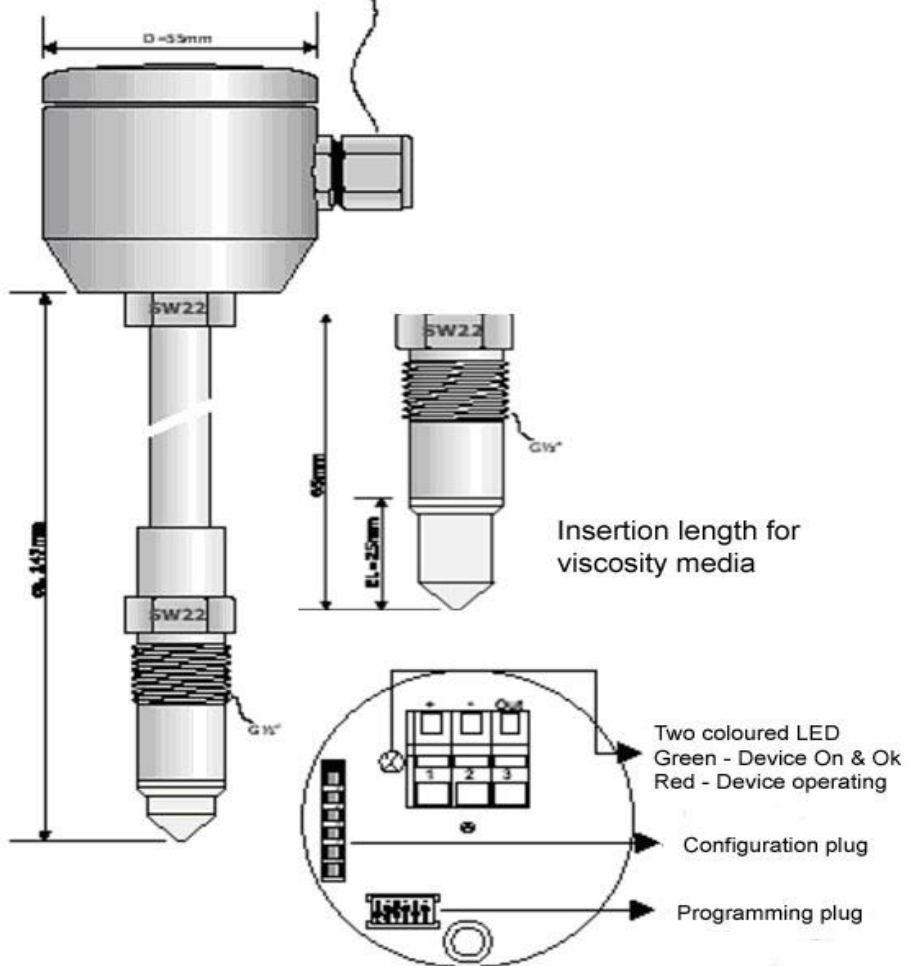

1 =	+
2 =	-
3 =	Out

Description KMW:

The hygienic level switch KMW is micro-processor based and can be installed in any position in tanks or piping systems. The measuring principle is an electromagnetic wave (100...180 MHz), a high frequency sweep is radiated from the sensor tip into the tank or pipe. The medium acts as a virtual capacitor, which together with the coil in the sensor, will form a circuit creating the switching point. This virtual capacity will depend of the dielectric value from the medium and is well defined for most medias. There are 7 basic settings for several medias. The sensitivity can be set in 2 different ways, by dipswitch or by the software with interface. With the interface it's possible to adjust the sensitivity of the unit to the particular medium. Adherence and passing-off characteristics of medias, can be shown by using the software. The process can be monitored and documented during a longer period. The standard configuration of the KMW is set to 0-0-0 and so it is ready for use in the most common liquids. There are some liquids that require some other settings.

The integration of the equipment into the process is made by hygienic welding sleeves or modular process adaptation. For the connection type G (1/2" BSP) the sleeve has got a trade-sign. This sign is positioned to the cable gland when it's mounted at a maximum of 10Nm. (the position of the trade-sign = position cable gland)

Visualization via PC-USB interface software.

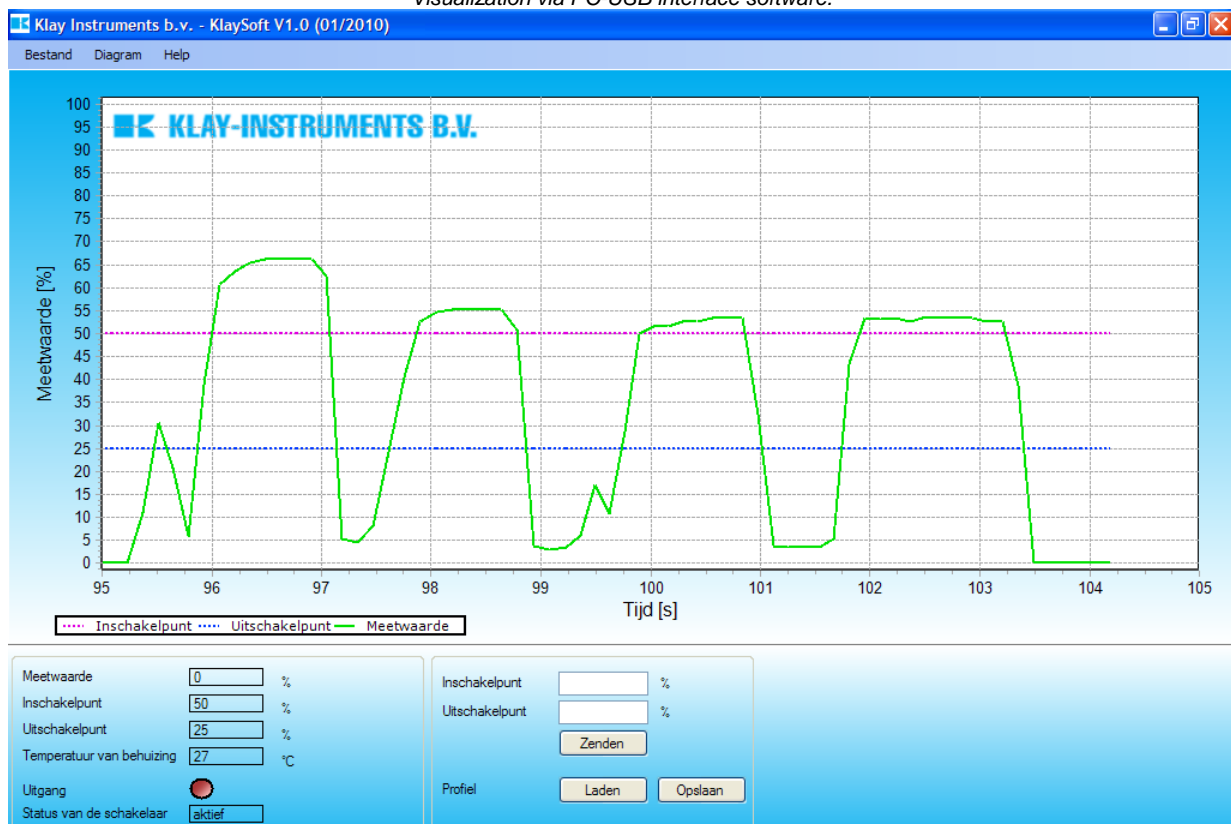

Ordering Code KMW:

		KMW	5	S	H
Electrical connection					
PG 9 gland	Protection class: IP67		5		
M12-plug	Protection class: IP68		6		
Hygienic connections					
1" BSP (hygienic) *				S	
Milkcoupling (DIN 11851)	DN25, DN40, DN50			M	
1/2" BSP				G	
Varivent	X4			X4	
Others, (specify)					

* to exchange 'tuning fork' level switch.

“LEVEL SWITCH”

KMW-6-S-H

1”BSP CONNECTION (SANITARY)

(Equal to ‘tuning fork’ level switch)

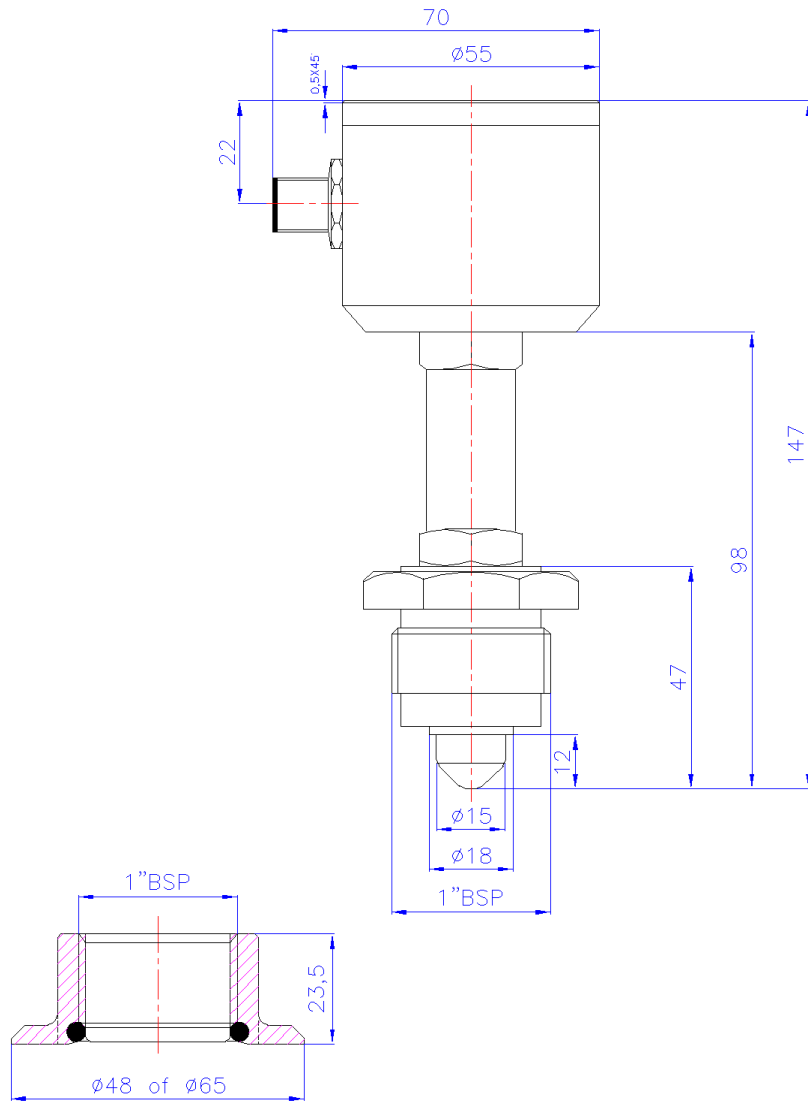

"LEVELSWITCH"

Type: KMW-6-G-H

1/2" BSP process connection (sanitary)

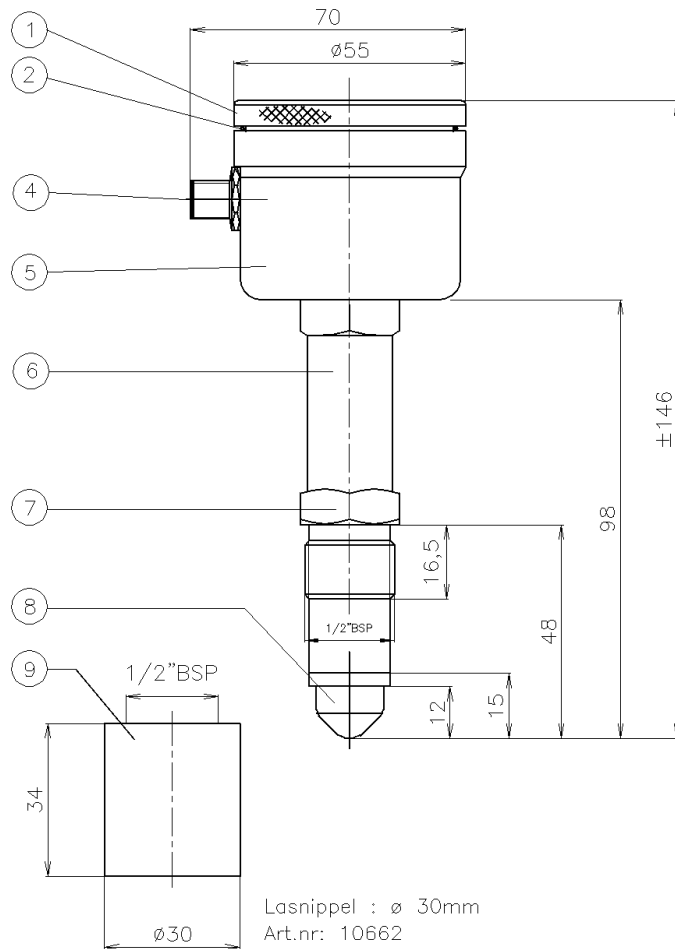

KLAY INSTRUMENTS B.V.

Nijverheidsweg 5
Postbus 13

7991 CZ Dwingeloo
7990 AA Dwingeloo Nederland

www.klay.nl

TEL.: +31(0)521-591550
FAX.: +31(0)521-592046

email: info@klay.nl