

Operating Instruction

VEGACAP

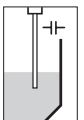
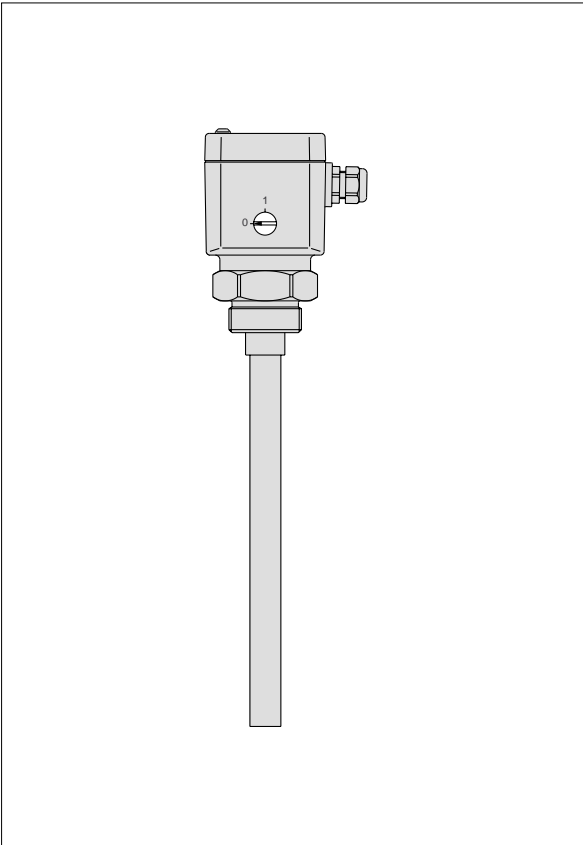

Safety information

The described module must only be installed and operated as described in this operating instruction. Please note that other action can cause damage for which VEGA does not take responsibility.

Contents

Safety information	2
1 Product description	
1.1 Function and configuration	4
1.2 Types and versions	6
1.3 Technical data	7
1.4 Dimensions	10
1.5 Product temperature and operating pressure	14
1.6 Approval	15
2 Mounting	
2.1 Mounting instructions	16
3 Electrical connection	
3.1 Connection instructions	21
3.2 Connection plan	21
4 Set-up	
4.1 Adjustment elements	24
4.2 Switch point adjustment	25
4.3 Functional table	28
5 Diagnosis	
5.1 Simulation	29
5.2 Maintenance	29
5.3 Repair	29
5.4 Exchange of electronics	29
5.5 Failure removal	30

1 Product description

1.1 Function and configuration

The capacitive compact level switches VEGACAP detect levels of virtually all mediums unaffected whether liquids, powders, granules or pastes. This is also valid for adhesive products.

VEGACAP can either detect exceeding or decreasing of a defined level.

Sensor, processing electronics and power supply form one unit in VEGACAP. The modular construction ensures the adaption to virtually any application. Beside rod, cable, high temperature and plate electrodes, there are also three electronics versions available (no-contact switch, relay or transistor output NPN/PNP).

VEGACAP 27, 35 and 98 combine all these positive features with the advantage that an adjustment with medium is no more necessary. This is possible with the oscillator CAP E31 R and the patented mechanical configuration of the electrode.

Application

The application area of VEGACAP is mainly in the detection of max. and min. levels in vessels. A switching command can be triggered either when the electrode is covered or uncovered. VEGACAP can be mounted laterally, from top or from bottom.

Partly insulated

The electrode is insulated via a defined length. The measurement is made on the not insulated area.

Fully insulated

The electrode is insulated along the entire length; on cable electrodes also the gravity weight can be insulated.

Measuring principle

Electrode, medium and vessel wall form an electrical capacitor.

The capacitance of the capacitor is generally influenced by three factors:

- distance of the electrode plates (a)
- size of the electrode plates (b)
- kind of dielectricum between the electrodes (c)

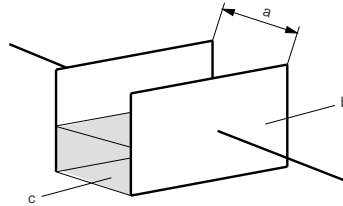

The electrode and the vessel wall are the capacitor plates. The medium is the dielectricum. Due to the higher dielectric constant figure (DK-value) of the medium against air, the capacitance of the capacitor increases with the covering of the electrode.

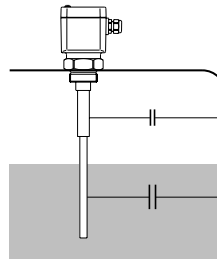

The capacitance change is converted by the oscillator into a switching command.

For adhesive products

(VEGACAP 26, 27, 35 and 98)

The special mechanical construction compensates conductive build-up. Leakage currents caused by build-up are drained off via the screen segment.

Even strong condensation or build-up do not influence the switching condition of VEGACAP.

The compensation of build-up is supported by the patented processing (phase selective admittance processing) in the oscillator CAP E31 R.

VEGACAP 35 can be shortened locally to the requested length. The planning and stock-keeping is facilitated.

Adjustment free

(VEGACAP 27, 35 and 98)

The set-up is very easy as the switch point must no more be adjusted.

Adjustment free means that varying mediums with different dielectric constant figures (ϵ_r), e.g. water and oil or conductive and non-conductive mediums do not influence the adjustments on VEGACAP and the switching accuracy.

With vertical installation, the switch point is only determined by the length of the electrode.

All products with a dielectric constant figure $\geq 1,5$ can be detected.

With horizontally installed electrodes, the installation position is also the position of the switch point.

1.2 Types and versions

Type survey

VEGACAP	11 ¹⁾	21	26	27	31 ¹⁾	33	34	35	42	52	53	60	61	82 ¹⁾	84	92	97	98
Series																		
Rod electrode	•	•	•	•								•					•	•
Cable electrode					•	•	•	•	•	•	•		•					
Plate electrode														•		•		
Pipe clamp electr.															•			
Version																		
Partly insulated	•				•	•	•	•				•	•	•				
Fully insulated		•	•	•					•	•	•					•	•	•
Thread																		
NPT 1 1/2"	•	•	•	•	•	•	•	•	•	•	•							
G 1 1/2 A	•	•	•	•	•	•	•	•	•	•	•	•	•					•
Electrode material																		
Steel	•	•	•	•	•	•	•	•	•	•	•	•	•			•		
StSt	•		•	•	•	•			•	•		•	•	•	•			
Isolation material																		
PTFE	•	•	•	•	•	•			•	•				•		•		
PP	•				•												•	•
PE/PA 12							•	•			•							
PFA		•	•	•														
PE		•																
Ceramic												•	•					
Temperature adapter																		
Steel	•	•	•	•	•	•				•								
StSt	•	•	•	•	•	•				•								
PA	•	•			•	•			•	•				•		•		
Others																		
Test switch	•	•	•		•	•	•		•	•	•	•	•	•	•	•	•	
Adhesive prod.			•	•					•								•	•
Adjustment free				•				•										•
High temp.version												•	•					

¹⁾ VEGACAP 11 R ExS, 31 R ExS and 82 R ExS with integral oscillator E30 R ExS are approved for StEx-applications.

1.3 Technical data

General

Housing

Housing material	plastic PBT (Polyester) VEGACAP 27, 35, 98 also Aluminium
Protection	plastic IP 66 (StEx IP 65) Aluminium IP 66/67
Cable entry	1 x Pg 13,5 (with oscillator R = 2 x Pg 13,5)
Terminals	for max. 1,5 mm ² cross-section area of conductor

Thread

Material	
- VEGACAP all except VEGACAP 97, 98	steel (St 37), 1.4571 (StSt), Aluminium
- VEGACAP 97, 98	PP
Thread	G 1 1/2 A or NPT 1 1/2" also flange or hygienic versions

Rod electrode (VEGACAP 11, 21, 26, 27, 60, 97, 98)

Rod material	
- VEGACAP 11, 21, 26, 27, 60	steel (St 37) or 1.4571 (StSt)
- VEGACAP 97, 98	PP
Length	
- VEGACAP 11, 21, 26, 27	max. 4 m
- VEGACAP 97, 98	max. 1,5 m

Cable electrode (VEGACAP 31, 33, 34, 35, 42, 52, 53, 61)

Cable material	
- VEGACAP 31, 33, 42, 61	steel (St 37) or 1.4571 (StSt)
- VEGACAP 34, 35, 52, 53	steel (St 37)
Length	max. 25 m

Weigth

Basic weight	
- VEGACAP 11, 21, 26, 27	approx. 1,2 kg
- 31, 33, 34, 35, 42, 52, 53, 60, 61	approx. 3,3 kg
- VEGACAP 82, 84, 92	approx. 2,1 kg
- VEGACAP 97, 98	approx. 0,6 kg
Rod weight	approx. 1,4 kg/m
Cable weight	
- all except VEGACAP 42	approx. 0,3 kg/m
- VEGACAP 42	approx. 0,1 kg/m

Ambient conditions

Ambient temperature on the housing	-40°C ... +70°C
- StEx-version	-20°C ... +60°C
Storage and transport temperature	-40°C ... +80°C
Medium temperature and operating pressure	see "1.5 Medium temperature and operating pressure"
Dielectric constant figure ϵ_r , medium	$\geq 1,5$

Function

Modes	A/B-mode A - max. detection or overflow protection B - min. detection or protection against dry running of pumps
Integration time	approx. 0,5 sec
Signal lamp	LED for indication of the switching mode
Test switch (option)	switch point simulation (not VEGACAP 27, 35, 98)

CE-conformity

VEGACAP compact level switches meet the protective regulations of EMVG (89/336/EWG) and NSR (73/23/EWG). The conformity has been judged acc. to the following standards:

EMVG	Emission	EN 50 081 - 1: 1992
	Susceptibility	EN 50 082 - 1: 1992
NSR		EN 61 010 - 1: 1993

CE-conformity (VEGACAP 27, 35, 98)

VEGACAP 27, 35 and 98 compact level switches meet the protective regulations of EMVG (89/336/EWG) and NSR (73/23/EWG). The conformity has been judged acc. to the following standards:

EMVG	Emission	EN 50 081 - 1: 1992
	Susceptibility	EN 50 082 - 2: 1992
NSR		EN 61 010 - 1: 1993

Oscillators

General

Frequency	400 kHz
Capacitance range (not for oscillator CAP E31 R)	
- range 1	0 ... 20 pF sensitive
- range 2	0 ... 85 pF ...
- range 3	0 ... 450 pF insensitive
Switching hysteresis	approx. 2 % relating to the adjusted capacitance value
Terminals	max. 1,5 mm ² cross-section area of conductor

C - Non-contact switch (CAP E30 C)

Supply voltage	20 ... 250 V AC, 50/60 Hz 20 ... 250 V DC
Output	non-contact switch
Domestic current requirement	< 5 mA (via the load circuit) for reliable switching off of contactors with very low hold current, the domestic current is shortly lowered below 1 mA.
Load current	min. 10 mA, max. 400 mA (4 A for 40 ms) at a load current of more than 300 mA the max. permissible ambient temperature is 60°C.
Protection class	I
Overvoltage category	III

R - Relay output (CAP E30 R)

Supply voltage	20 ... 250 V AC, 50/60 Hz 20 ... 72 V DC
Power consumption	1 ... 9 VA, max. 1,5 W
Output	relay output (SPDT)
Relay data	
- potential separation	min. 500 V DC
- contact	floating spdt
- contact material	AgCdO and Au plated
- turn-on voltage	min. 10 mV max. 250 V AC, 250 V DC
- switching current	min. 10 μ A max. 3 A AC, 1 A DC
- breaking capacity	max. 500 VA, 54 W
Protection class	I
Overvoltage category	III

R - Relay output (CAP E31 R)

Supply voltage	20 ... 250 V AC, 50/60 Hz 20 ... 72 V DC
Power consumption	1 ... 9 VA, max. 1,5 W
Output	relay output (DPDT)
Relay data	
- potential separation	min. 500 V DC
- contact	2 floating spdt
- contact material	AgCdO and Au plated
- turn-on voltage	min. 10 mV max. 250 V AC, 250 V DC
- switching current	min. 10 μ A max. 5 A AC, 1 A DC
- breaking capacity	max. 750 VA, 54 W
Protection class	I
Overvoltage category	III

T - Transistor output (CAP E30 T)

Supply voltage	10 ... 55 V DC
Power consumption	max. 0,5 W
Output	floating transistor output NPN/PNP, individually selectable by different coordination
Load current	max 400 mA (the output is overload resistant and permanently shortcircuit proof)
Blocking current	max. 10 μ A
Voltage loss	max. 1 V (if output conductive)
Protection class	II
Overvoltage category	III

Note:

The oscillator is independent of the electrode and can be replaced locally. Set the changeover switch of the new oscillator to the same position and repeat the switch point adjustment.

Survey

VEGACAP	11	21	26	27	31	33	34	35	42	52	53	60	61	82	84	92	97	98	11 StEx	31 StEx	82 StEx	
Non-contact switch CAP E30 C	•	•	•		•	•	•		•	•	•	•	•	•	•	•	•					
Floating relay output CAP E30 R, E30 R ExS	•	•	•		•	•	•		•	•	•	•	•	•	•	•	•		•	•	•	
Floating relay output CAP E31 R				•				•									•					
Floating transistor output CAP E30 T	•	•	•		•	•	•		•	•	•	•	•	•	•	•	•					

1.4 Dimensions

VEGACAP 11 (partly insulated)

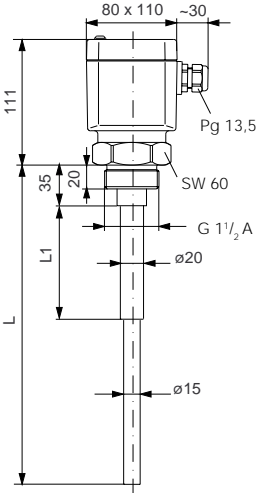

Isolation length L1:
 (VEGACAP 11 and VEGACAP 31)
 PP: 100 mm
 PTFE: 50 mm
 StEx: max. 100 mm

VEGACAP 21 (fully insulated)

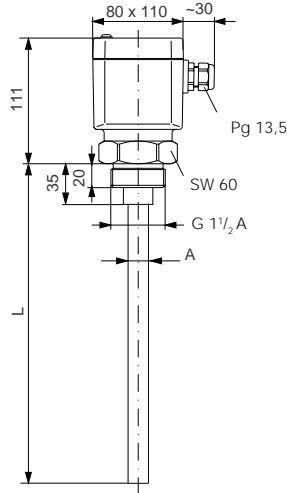

Isolation		A outer-ø
PE	2,0 mm	20 mm
PTFE	2,0 mm	20 mm
PTFE	3,2 mm	16 mm
PFA	2,0 mm	20 mm

VEGACAP 26 (fully insulated, for adhesive products)

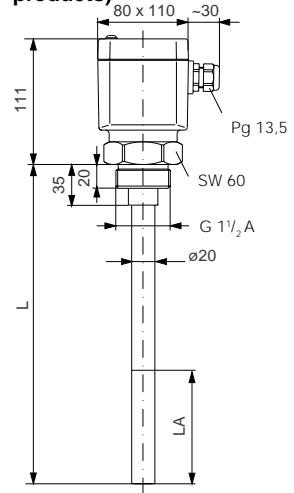

LA = active length (standard 100 mm)

VEGACAP 27 (fully insulated, for adhesive products, adjustment free)

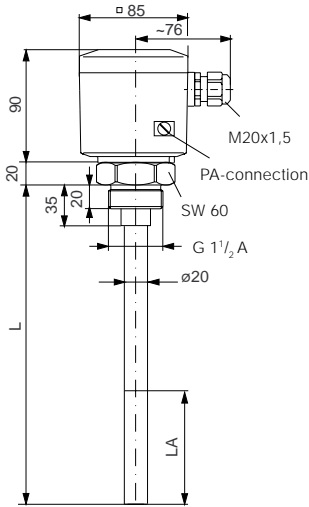

VEGACAP 31 (partly insulated)

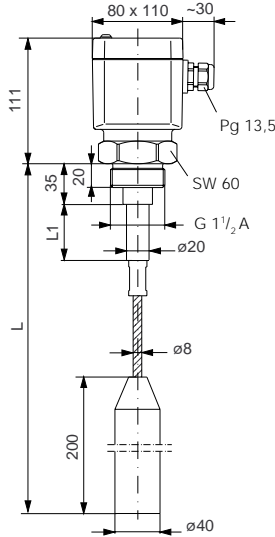

VEGACAP 33 (partly insulated)

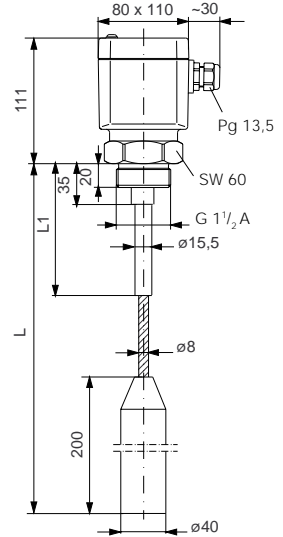

VEGACAP 34 (partly insulated)

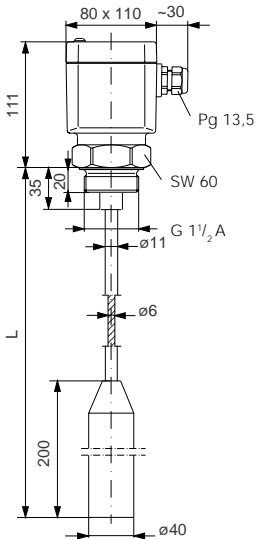

VEGACAP 35 (partly insulated, for adhesive products, adjustment free)

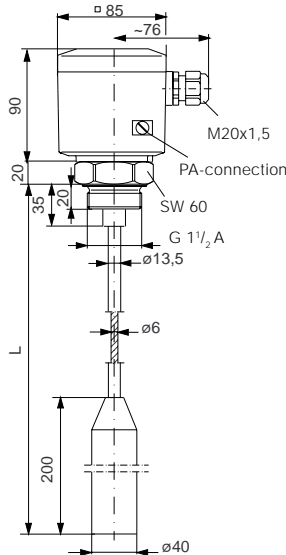

VEGACAP 42 (fully insulated)

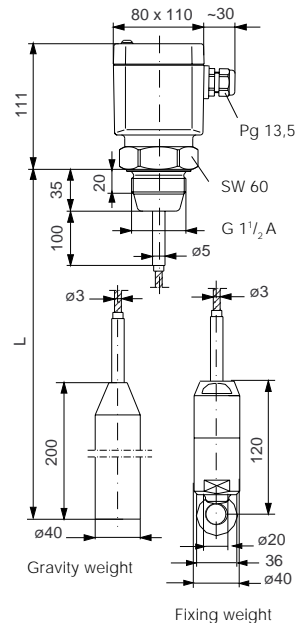

VEGACAP 52 (fully insulated)

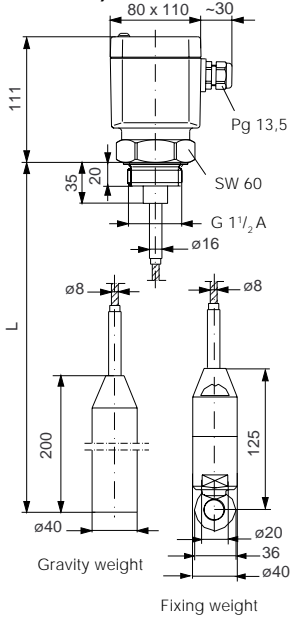

VEGACAP 53 (fully insulated)

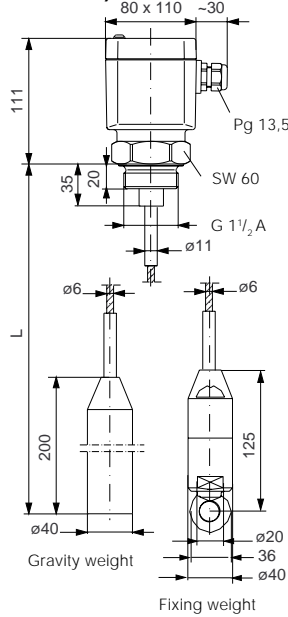

VEGACAP 82 / VEGACAP 92 (partly / fully insulated)

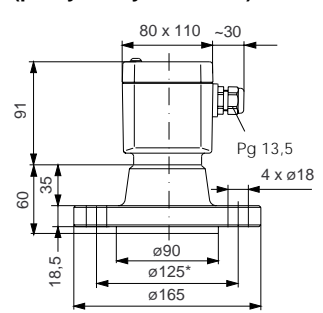

VEGACAP 84

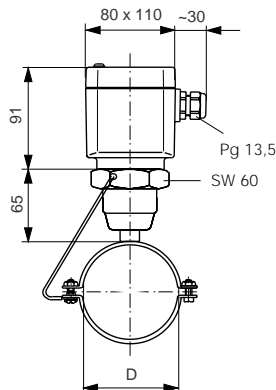

VEGACAP 97 (fully insulated, for adhesive products)

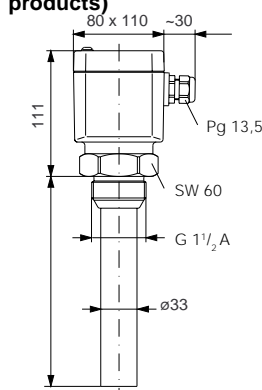

VEGACAP 98 (fully insulated, for adhesive products, adjustment free)

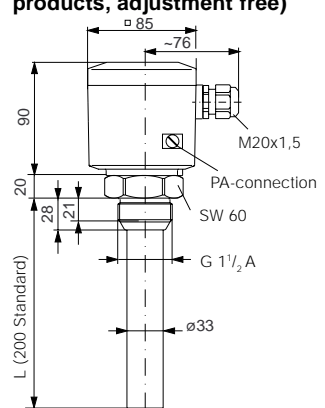

**Temperature adapter
St / StSt**

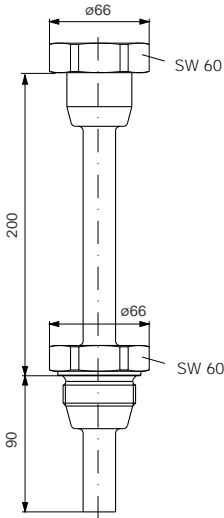

Temperature adapter PA

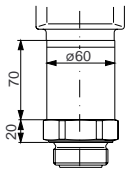

for temperatures
up to 150°C,
from 100°C only
unpressurized

Screening tube

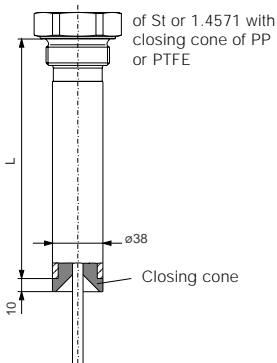

**VEGACAP 60 (partly
insulated, high temperature
electrode)**

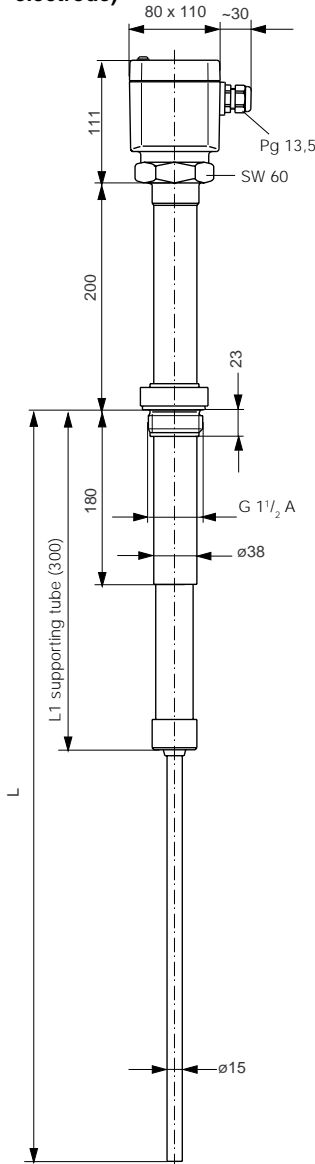

**VEGACAP 61 (partly
insulated, high temperature
electrode)**

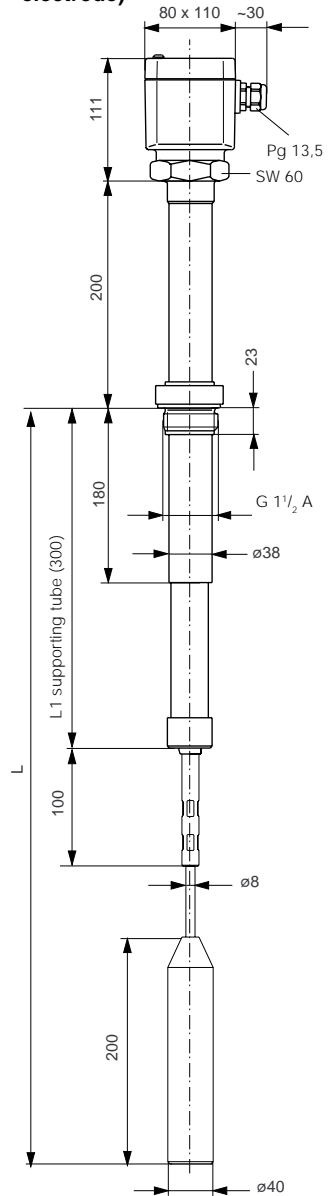

1.5 Product temperature and operating pressure

The figures of the tables relate each to the following figures. The pressure stated is valid for thread connections G 1 1/2 A, NPT 1 1/2" and R 1 1/2. Boltings DN 50 acc. to DIN 11 851 only up to max. 25 bar. For flange versions you have to note their nominal pressure. All electrodes are also suitable for vacuum (-1 bar).

Mechanical connection, 1.4571 (StSt)

Isolation	PE	PP	PTFE	PE/PA 12	PFA
VEGACAP					
11	-	1	3	-	-
21	1	-	3	-	3
21 ²⁾	-	-	2	-	-
26	-	-	3	-	3
26 ²⁾	-	-	2	-	-
27	-	-	3	-	3
31	-	1	3	-	-
33	-	-	3	-	-
34 unpressurized	-	-	-	1	-
35	-	-	-	1	-
42	-	-	2	-	-
52	-	-	3	-	-
53	-	-	-	1	-

Mechanical connection, steel (St 37)

Isolation	PE	PP	PTFE	PE/PA 12	PFA
VEGACAP					
11	-	4	6	-	-
21	4	-	6	-	6
21 ²⁾	-	-	5	-	-
26	-	-	6	-	6
26 ²⁾	-	-	5	-	-
27	-	-	6	-	6
31	-	4	6	-	-
33	-	-	6	-	-
34 unpressurized	-	-	-	4	-
35	-	-	-	4	-
42	-	-	5	-	-
52	-	-	6	-	-
53	-	-	-	4	-

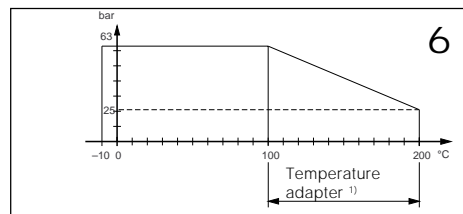
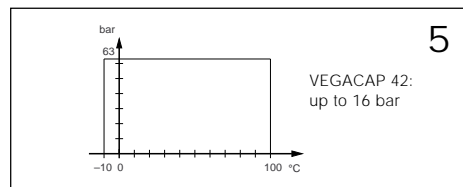
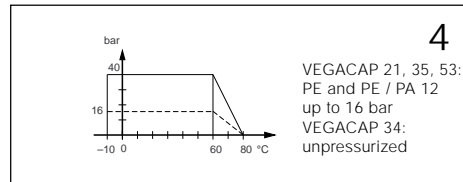
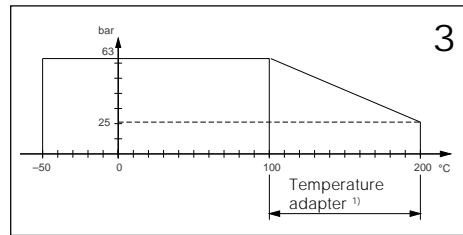
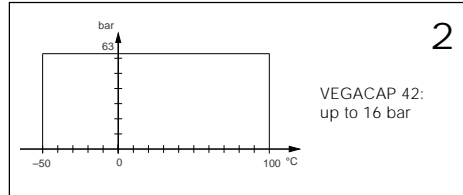
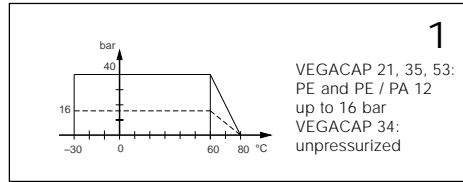

¹⁾ Temperature adapter of PA up to 150°C, from 100°C unpressurized

²⁾ Flange plated

Mechanical connection, Aluminium
(VEGACAP 97, 98: PP)

Isolation VEGACAP	PE	PP	PTFE	PE/PA 12	PFA
11	-	7	8	-	-
21	7	-	8	-	8
26	-	-	8	-	8
27	-	-	8	-	8
31	-	7	8	-	-
33	-	-	8	-	-
34 unpressurized	-	-	-	7	-
35	-	-	-	7	-
42	-	-	8	-	-
52	-	-	8	-	-
53	-	-	-	7	-
82 unpressurized	-	-	9	-	-
84 unpressurized	-	-	-	-	-
92	-	-	9	-	-
97	-	7	-	-	-
98	-	7	-	-	-

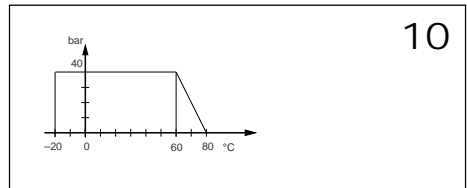
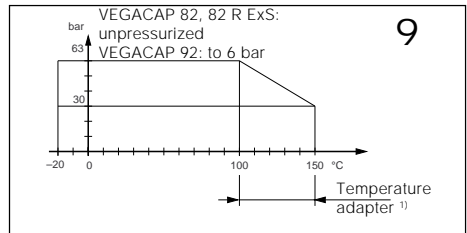
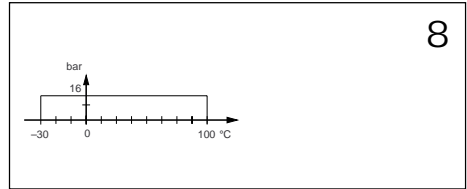
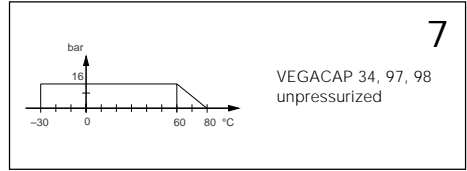

Instruments with StEx-approval

Mechanical connection, steel (St 37) or 1.4571 (StSt)

Isolation VEGACAP	PP	PTFE
11 R ExS	10	9
31 R ExS	10	9
82 R ExS unpressurized	-	9

¹⁾ Temperature adapter of PA up to 150°C, from 100°C unpressurized

1.6 Approval

StEx (Zone 10)

Level detection

Instrument	Oscillator	Level switch	Certificate
Capacitive VEGACAP 11 R ExS.- 31 R ExS.- 82 R ExS.-	E30 R ExS	Signal conditioning instrument not required, as compact instrument	BVS-no. 95.Y.8001

2 Mounting

2.1 Mounting instructions

General

Generally the instrument can be installed in any individual position. The instrument must be just mounted such that the electrode is at the height of the requested switch point. Various mediums and requirements to the measurement require different kinds of installation. Hence some instructions should be noted.

Length of the electrode

Note already when ordering electrodes for vertical installation, that the electrode must be covered at the requested level according to the electrical feature of the medium.

Note that the switch point of vertically installed, adjustment free electrodes (VEGACAP 27, 35, 98) can vary in a range of 5 cm.

Lateral load

Note that the electrode is not subjected to strong lateral forces. Mount VEGACAP at a position in the vessel where no interferences such as e.g. stirrers, filling openings etc. can occur (see fig. 2.1).

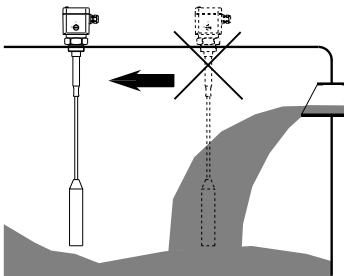

Fig. 2.1

Plate electrode

Install the plate electrode (VEGACAP 82, 92) such that the electrode is flush to the vessel wall. The wall thickness of the vessel should not exceed 20 mm. Chamfer the inner edge of the hole so that build-up can be avoided.

Shortening of the electrode

Fully insulated electrodes have fixed dimensions and must hence not be modified in their dimensions. Each modification will destroy the instrument.

All partly insulated electrodes can be shortened. The electrodes are compensated to the appropriate electrode length with the factory setting. If the electrode will be shortened by more than 30 %, you should recompensate the electrode. Call our service.

VEGACAP 35 can be shortened individually. There is no need of recompensation.

If electrodes with a length of more than 2 m, are shortened by more than 30 %, an empty adjustment must be carried out. Shorter electrodes do not require a readjustment. The appropriate instruction is under "4.2 Switch point adjustments".

VEGACAP 31, 33 and 34 cable electrodes can be shortened afterwards (see fig. 2.2).

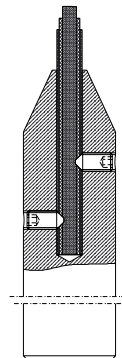

Fig. 2.2

Shortening instruction for VEGACAP 31, 33 and 34

- Loosen the two pins on the gravity weight (hexagon socket) and remove the two pins.
- Pull the cable out of the gravity weight.
- To avoid splicing of the steel cable during cutting, you have to tin the cable approx. 5 cm around the cutting position with a copper bit or strongly tighten the cable together with a wire.
- Shorten the electrode cable with a metal cutting saw or a cutting-off wheel. Isolated cable must not be tinned as it cannot splice.
- Shift the cable into the hole of the gravity weight (isolated cables: with the isolation) and clamp the cable with the two pins. With isolated electrode cable, the tips of the two pins must go through the cable isolation to ensure contact of the gravity weight with the metal cable.
- Carry out an adjustment. The instruction is under "4.1 Adjustment".

When the cable will be considerably shortened, it can happen that the electrode cannot be adjusted. In this case the electrode must be recompensated. Note the serial number of the electrode and call one of our technicians.

VEGACAP 35 cable electrode can be also shortened afterwards (see fig. 2.3).

Shortening instruction for VEGACAP 35

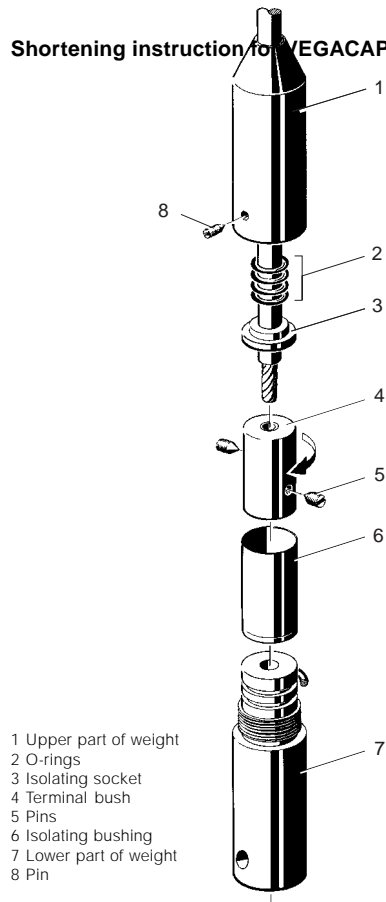

Fig. 2.3

- Loosen the outer pin (8).
- Unscrew the upper part of the weight (1).
- Shift the upper part of the weight (1), the four O-rings (2) and the isolating socket (3) on the cable to the top above the planned intersection point.
- Remove the isolating bushing (6) from the terminal bush (4).
- Loosen the two pins (5) on the terminal bush

(4) and pull out the cable.

- Shorten the electrode cable with a metal cutting saw or a cutting-off wheel to the requested length.
- Shorten the cable isolation with a sharp knife by 60 mm.
- Shift the chamfered side of the terminal bush (4) with a rotational movement to the cable.
Note that the cable is flush with the lower side of the terminal bush (4).
- Fasten the cable with the two pins (5).
Note that the screen of the electrode cable has no contact to the inner steel cable.
- Shift the isolating bushing (6) to the terminal bush (4).
- Shift the upper part of weight (1) again to the lower part of weight (7) and screw the two parts together.
- Secure the upper part of weight (1) with the outer pin (8).
- Carry out an adjustment. Instruction under "4.2 Switch point adjustment".

Extracting forces

In case of strong extracting forces e.g. due to material inflow, high tensile loads can be caused.

In this cases use for short meas. distances a rod electrode, as generally a rod is more stable. If due to the length or the installation position a cable electrode should be necessary, the electrode should not be fixed but just provided with a gravity weight as the cable can more easily follow the product movements. Note that the electrode cable does not touch the vessel wall.

Pressure

In case of excess or low pressure in the vessel, the mounting boss must be sealed on the housing. Use the attached seal ring. Check whether the seal ring is resistant against the medium.

Isolating measures such as e.g. the covering of the thread with Teflon tape can interrupt the necessary electrical connection in metal vessels. Hence earth the electrode with an additional cable connection to the vessel.

Aluminium vessel

In case of Aluminium vessels an electrode with steel thread should be used. The combination Aluminium on Aluminium should be avoided as the thread "seizes" and can no more be removed after some time without damage.

Horizontal mounting

The electrode can be mounted horizontally to reach an exact switch point with level detection. We recommend to mount the electrode approx. 20° inclined to the bottom so that build-up is avoided (see fig. 2.4).

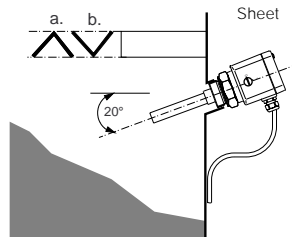

Fig. 2.4

Humidity

When mounting outside, on cooled vessels or in humid areas where the cleaning is e.g. made with steam or high pressure, the sealing of the cable entry is very important. Use cable with sufficient cross-section area of conductor and tighten the cable entry very well. For cables with too small cross-section area of conductor, an appropriate reduction piece must be used to ensure tightness.

Two different seal rings are attached to the instrument to reliably seal also cables with smaller diameter in the cable entry. Use the smallest possible seal ring.

Turn the cable entries of the instrument to the bottom to avoid humidity ingress. The instrument housing is hence rotational by approx. 330°. For vertically installed electrodes loop the connection line to the instrument housing to the bottom so that rain and condensation water can drain off (see fig. 2.5).

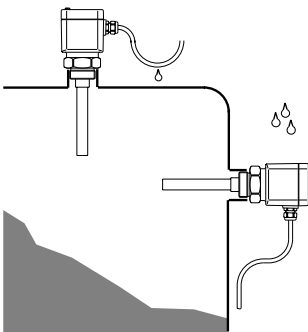

Fig. 2.5

Metal vessels

Note that the mechanical connection of the electrode is electrically conductive connected with the vessel to ensure sufficient earth.

Use conductive seals such as e.g. copper, lead etc. Isolating measures such as covering of the thread with Teflon tape can interrupt the necessary electrical connection. In this case use the earth terminal on the housing to connect the electrode to the vessel wall.

Non-conductive vessels

In non-conductive vessels, e.g. plastic tanks, the second pole of the capacitor must be provided separately, e.g. by a concentric tube or earth rod.

Under suitable earth conditions (e.g. short electrodes) the earth plates or a concentric tube can be deleted.

When using a standard electrode, a suitable earth plate is necessary. Hence provide a possibly large earth plate e.g. wire braiding laminated into the vessel wall or a metal foil which is glued to the vessel. Connect the earth plates with the earth terminal on the instrument housing.

Filling opening

Install the electrode such that it does not protrude directly into a strong filling stream. Should such an installation place be necessary, mount a suitable sheet above or in front of the electrode e.g. L 80 x 8 DIN 1028, etc. (see fig. 2.4 a).

In abrasive solids, mounting acc. to fig. 2.4 b has proven. In the concave sheet a material cone is generated avoiding wear of the sheet.

Mounting boss

Install the rod electrode (VEGACAP 11, 21, 26, 97) such that the electrode protrudes into the vessel. When being installed in a tube or a socket, build-up can be caused which can influence the measurement. This is particularly due for viscous or adhesive products (see fig. 2.6).

In case of longer sockets, choose an electrode for adhesive products (VEGACAP 26, 27, 35, 97, 98) or a screening tube.

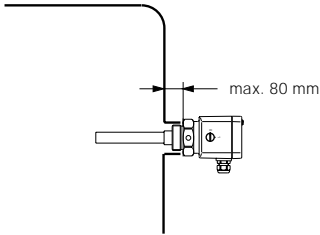

Fig. 2.6

Material cone

Note when installing the electrodes into the vessel, that material cones can be caused with solids which can change the switch point. We recommend to choose an installation place where the electrode detects an average value of the material cone.

According to the position of the filling and emptying opening in the vessel, the electrode must be installed appropriately. To compensate meas. errors caused by the material cone, you should install the electrode at a distance of approx. d_{10} from the vessel wall. You should keep a min. distance of approx. 20 cm (see fig. 2.7 and 2.8).

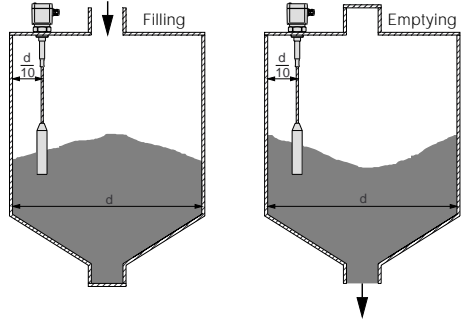

Fig. 2.7 Material cone, filling and emptying centered

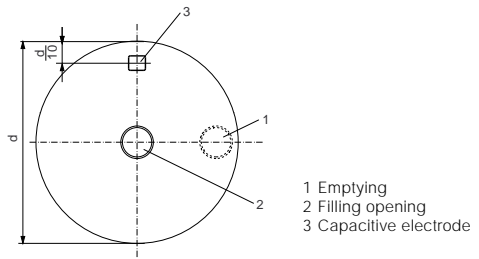
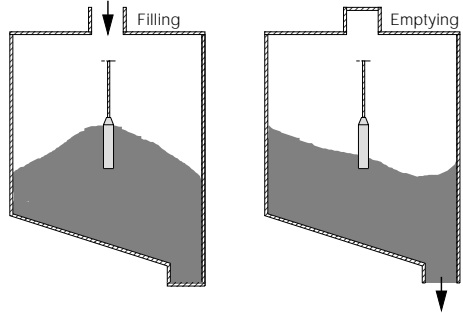

Fig. 2.8 Material cone, filling centered, emptying lateral

3 Electrical connection

3.1 Connection instructions

Danger

Switch off the power supply before starting connection work.

The electrical connection must be carried out dependent on the integral oscillator. Connect mains voltage acc. to the following connection plans.

Note

Note when placing the housing cover that the inspection glass is above the control lamp (LED).

Note

If strong electromagnetic interferences have to be expected, we recommend to use screened cable. The screening of the cable should only be earthed at one sensor end (electrode).

Generally connect VEGACAP with vessel ground (PA). For this purpose there is a thread (screw M4 x 5) laterally on the hexagon of the mounting boss. This connection is used to drain off electrostatic discharge.

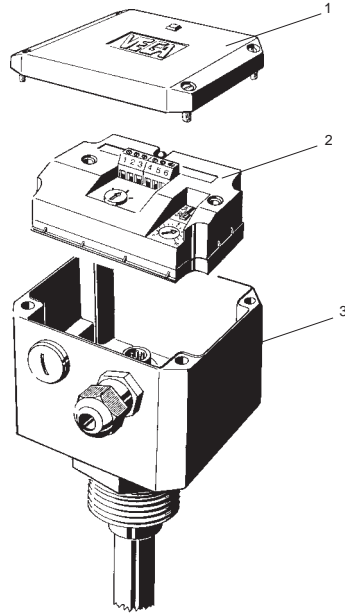

- 1 Housing cover
- 2 Oscillator CAP E30
- 3 Housing

Oscillator CAP E31 R

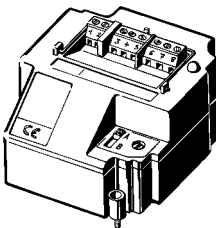

3.2 Connection plan

Non-contact switch (CAP E30 C)

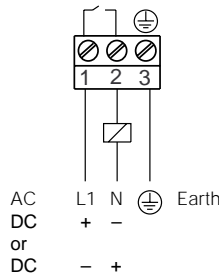

Voltage supply: 20 ... 250 V AC, 50/60 Hz; 20 ... 250 V DC (for further information see technical data)

For direct control of relays, contactors, magnetic valves, signalers, horns etc. Must not be operated without connected load (switching in series) as the oscillator will be destroyed when directly connected to mains. Not suitable for connection to low voltage DCS-inputs. The domestic current is shortly lowered below 1 mA when switching off the load, so that contactors, the holding current of which is lower than the permanently flowing domestic current of the electronics, nevertheless can be switched off reliably.

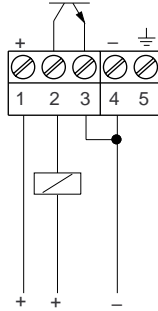

NPN-action

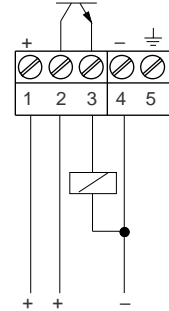

PNP-action

Floating transistor output (CAP E30 T)

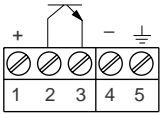

Voltage supply: 10 ... 55 V DC
(for further information see the following switching examples as well as the technical data)

Switching examples

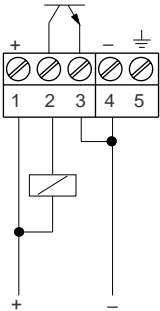

NPN-action

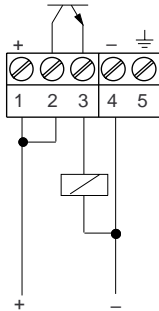

PNP-action

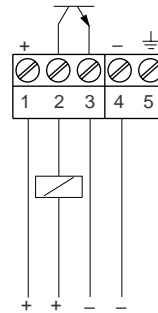

NPN-action

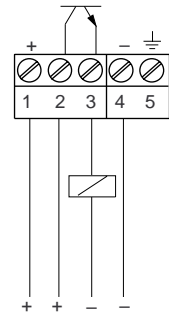

PNP-action

The transistor switches a second voltage source with the same reference potential to the binary input of a DCS or to an electrical load. Due to different connection of the consumer (load) PNP or NPN-action can be reached.

The transistor switches a second, galvanically separated voltage source to the binary input of a DCS or to an electrical load. Due to different connection of the consumer (load) PNP or NPN-action can be reached.

The transistor switches the supply voltage of the oscillator to the binary input of a DCS or to an electrical load. Due to different connection of the consumer (load) PNP or NPN-action can be reached.

Control of alternating current loads

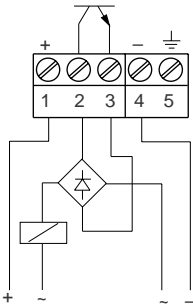

The transistor switches a galvanically separated alternating voltage 10 ... 42 V AC to a load.

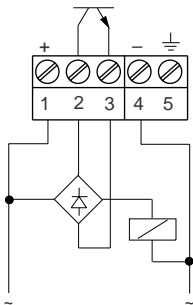

The transistor switches an alternating voltage 10 ... 42 V AC, which is also supply voltage to a load.

Note

The transistor outputs of several VEGACAP can be switched in series to connect the signals logically. The wiring must be made such that terminal 2 has always higher voltage against terminal 3.

Floating relay output (CAP E30 R)

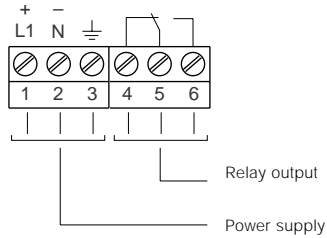

Voltage supply: 20 ... 250 V AC, 50/60 Hz; 20 ... 72 V DC (for further information see technical data)

Is used to switch external voltage sources to relays, contactors, magnet valves, signallers, horns etc.

Floating relay output (CAP E31 R)

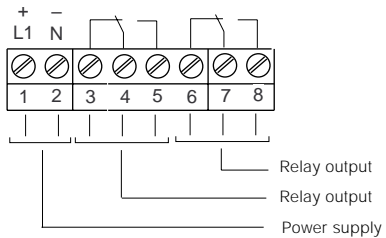

Voltage supply: 20 ... 250 V AC, 50/60 Hz; 20 ... 72 V DC (for further information see technical data)

In conjunction with oscillator CAP E31 R the electrodes VEGACAP 27, 35 and 98 are adjustment free and suitable for adhesive products.

With double relay (DPDT), i.e. both relays carry out the same switching function, e.g. common control of a horn and a magnet valve.

4 Set-up

4.1 Adjustment elements

Oscillator CAP E30

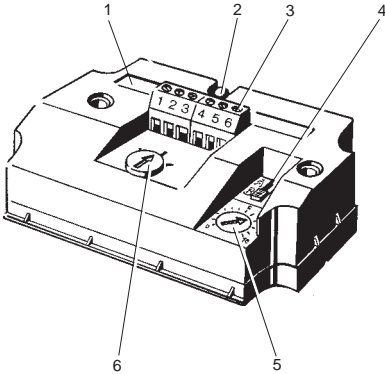

- 1 - Type plate (oscillator)
- 2 - Control lamp (LED)
- 3 - Terminals
- 4 - A/B-switch
- 5 - Potentiometer
- 6 - Changeover switch

Fig. 4.1

Oscillator CAP E31 R

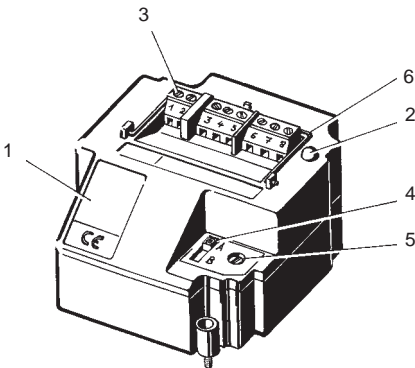

- 1 - Type plate (oscillator)
- 2 - Control lamp (LED)
- 3 - Terminals
- 4 - A/B-switch
- 5 - Potentiometer
- 6 - Strap

Fig. 4.2

The switching mode of the electronics can be checked with closed housing (2) (only plastic housing) see "4.3 Functional table". For adjustment of VEGACAP loosen the four screws on the instrument top by means of a screwdriver and remove the housing cover.

The following adjustments are possible on oscillator CAP E30:

- A/B-mode
- switch point adjustment
- range selection.

With the A/B-switch (4) you can change the switching mode of the non-contact switch (C), the relay (R) or the transistors (T). You can hence adjust the requested mode acc. to "4.3 Functional table".

A - Max. detection or overflow protection, B - min. detection or detection against dry running of pumps.

With the potentiometer (5) and the changeover switch (6) you can modify the switch point of the electrode or adapt the sensitivity of the electrode to the electrical features of the medium and the conditions in the vessel. This is necessary that the level switch can reliably detect e.g. products with very low or very high dielectric constant value (DK = dielectric constant figure). On oscillator CAP E31 R this adjustment is not necessary.

Capacitance range

(oscillators CAP E30 C, R, T)

- range 1 0 ... 20 pF sensitive
- range 2 0 ... 85 PF ...
- range 3 0 ... 450 pF insensitive

Examples for DK-values:

Air = 1, Oil = 2, Acetone = 20, Water = 81 etc.

Turn the potentiometer anticlockwise to adjust the electrode more sensitive.

Note

When positioning the housing cover note that the inspection glass is above the control lamp (LED).

4.2 Switch point adjustment

With the A/B-switch (4) you can choose the mode of VEGACAP - whether the level switch should be used as max. detection A (overflow protection) or min. detection B (protection against dry running of pumps). The switch point adjustment is generally only possible in assembled condition. The information in brackets relate to the figure "4.1 Adjustment elements".



Horizontally mounted electrodes, electrodes for adhesive products, plate electrodes, bent electrodes

(with oscillator CAP E30..., fig. 4.1)
(VEGACAP 11, 21, 26, 60, 61, 82, 84, 92, 97)

Mode A / [mode B]

- Make sure that the test switch (outside on the housing - option) is set to position 0.
- Set the A/B-switch (4) to mode A [B].
- Set the changeover switch (6) to position 1.
- Make sure that the electrode is uncovered.
- Turn the potentiometer (5) to 0; the control lamp (2) lights [extinguishes].
- Turn the potentiometer (5) very slowly clockwise until the control lamp extinguishes [lights], to determine the empty switch point. If the lamp does not extinguish [light], set the changeover switch to the next higher stage and repeat the adjustment with the potentiometer until the control lamp extinguishes [lights].
- Note the position of the potentiometer (5). In some cases the lowest range (range 1 = highest sensitivity) is not sufficient to adjust the full switch point. This would require another filling procedure.
For this purpose we recommend to adjust and note the empty switch point in all three ranges.

- Set the changeover switch (6) to the next higher position and repeat the adjustment. Note the value for the next higher range.

	 Empty adjustment	 Full adjustment
Range 1		
Range 2		
Range 3		

- Set the changeover switch (6) to the lowest range where the control lamp extinguishes [lights].
- Fill the vessel until the electrode is completely covered.
- Turn the potentiometer (5) very slowly clockwise until the control lamp extinguishes [lights]. Note the position of the potentiometer (5). We recommend to document the value of the empty and full switch point as well as the range.
- If the lamp does not extinguish [light], set the changeover switch (6) to the next higher stage and repeat the adjustment with the potentiometer until the control lamp extinguishes [lights].
- Set the potentiometer (5) to the average value of the two noted values. The measuring system is now ready for operation.
- If you cannot find the full switch point in one of the ranges, we recommend to set the changeover switch (6) to the lowest range in which you have found the empty switch point. Set the potentiometer (5) to the average value between empty switch point and 10.

Vertically mounted electrodes

(with oscillator CAP E30..., fig. 4.1)

(VEGACAP 11, 21, 31, 33, 34, 42, 52, 53, 60, 61)

Mode A

(Max. detection)

- Make sure that the test switch (outside on the housing - option) is set to position 0.
- Set the A/B-switch (4) to mode A.
- Set the changeover switch (6) to position 1.
- Fill the vessel to the requested level.
- Turn the potentiometer (5) to 10; the control lamp (2) extinguishes.
- Turn the potentiometer (5) very slowly anticlockwise until the control lamp (2) lights. If the control lamp does not light, set the changeover switch (6) to the next higher stage and repeat the adjustment with the potentiometer until the control lamp lights. The measuring system is ready for operation.

Mode B

(Min. detection)

- Make sure that the test switch (outside on the housing - option) is set to position 0.
- Set the A/B-switch (4) to mode B.
- Set the changeover switch (6) to position 1.
- Lower the product up to the requested min. level.
- Turn the potentiometer (5) to 0; the control lamp (2) extinguishes.
- Turn the potentiometer very slowly clockwise until the control lamp (2) lights. If the control lamp does not light, set the changeover switch (6) to the next higher stage and repeat the adjustment with the potentiometer until the control lamp lights. The measuring system is ready for operation.

Adjustment free electrodes for adhesive products

(with oscillator CAP E31 R, fig. 4.2)

In conjunction with oscillator CAP E31 R the electrodes VEGACAP 27, 35 and 98 (up to max. 3 m) must generally no more be adjusted (see exceptions on the following pages). The vessel must not be filled for the adjustment.

With the A/B-switch (4) you can choose the mode of VEGACAP whether the level switch should be used as max. detection A (overflow protection) or min. detection B (protection against dry running of pumps).

These electrodes have an active length and a screening segment. Due to this small active length, the standing capacitance caused by the vessel after the installation of the electrode will be nearly compensated.

The oscillator is adjusted to the basic capacitance of the electrode. The level switch switches with the first 2 ... 5 cm covering of the electrode. Varying dielectric constant values of the products such as e.g. in mixing vessels are no problem for the switching accuracy within this limit. The selection of the electrode length is hence very important as the length determines the switch point which cannot be shifted on the electrode (exception: the electrode of VEGACAP 35 can be shortened).

The electrodes can be produced with different high resistance isolations and are hence suitable for aggressive products (see also "1.2 Types and versions").

The electrodes VEGACAP 27, 35 and 98 are furthermore insensitive to adhesions.

Exceptions

In limited cases, e.g. in pipelines or when the electrode is mounted very close to the vessel wall or where high standing capacitances exceed the preadjustment of VEGACAP, it can happen that the electrode signals overfilling (covered) even if the electrode is uncovered. The oscillator of VEGACAP must be readjusted.

In the following cases a new adjustment is necessary:

- in case of electrodes with a length of more than 3 m
- in case of narrow installation conditions with high standing capacitance (pipes etc.),
- in products with very low dielectric constant values
- after shortening of the cable electrode VEGACAP 35 by more than 30 % when the cable length is > 2 m
- after exchange of the oscillator.

Mode A/B

- Make sure that the electrode is uncovered.
- Push through the glueing cover, as on figure 4.3, with a screwdriver.
- Turn the below potentiometer first some turns anticlockwise.
- Turn the potentiometer very slowly clockwise until the control lamp:
 - mode A (overflow protection) - control lamp extinguishes
 - mode B (protection against dry running of pumps) - control lamp lights
- Then turn the potentiometer acc. to the following table clockwise. The instrument is ready for operation.

Sensitivity	Standard	very sensitive
	VEGACAP 27, 98	DK > 2 2,5 turns
VEGACAP 35	DK > 1,5 3,5 turns	

Note

For the measurement of products with very low dielectric constant values the figure of turns can be reduced to 1. However note that this adjustment is too sensitive for conductive, adhesive products.

Note

Note when positioning the housing cover, that the inspection glass is above the control lamp (LED).

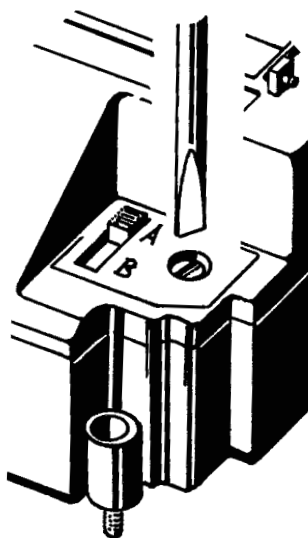
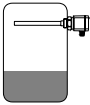



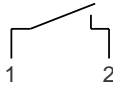
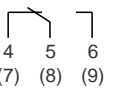

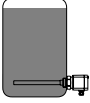
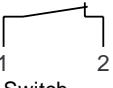
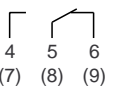

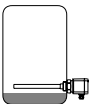
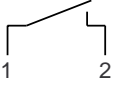
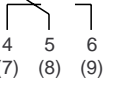

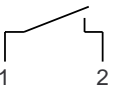
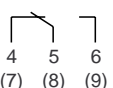



Fig. 4.3

4.3 Functional table

The following table gives a survey on the switching conditions dependent on the adjusted mode and level.

	Level	Switching condition			Control lamp VEGACAP
		CAP E30 C	CAP E30 R CAP E31 R	CAP E30 T	
Mode A		 Switch closed	 Relay energized	Transistor conductive	
		 Switch open	 Relay de-energized	Transistor blocks	
Mode B		 Switch closed	 Relay energized	Transistor conductive	
		 Switch open	 Relay de-energized	Transistor blocks	
Failure of the supply voltage	individual	 Switch open	 Relay de-energized	Transistor blocks	

5 Diagnosis

5.1 Simulation

Test switch (option)

Optionally a test switch can be integrated in the housing to simulate a switching condition.

By pushing the test switch an additional capacitance is provided. Hence the function of the oscillator and the connected instruments are tested.

The information in brackets relates to the figure "Adjustment elements".

Note

When the changeover switch (6) is set to position 3, it can be possible that the provided capacitance is not sufficient, to carry out a test.

The test switch can only be used for simulation of a max. level (overflow protection).

Test

- Make sure that the A/B-switch (4) is set to position A. In normal operation the test switch is set to position 0.
- Set the test switch to position 1. The changeover of the test switch to position 1 increases the capacitance of the uncovered electrode so that the oscillator responds and triggers an alarm message; the control lamp (2) lights and the connected instruments are activated.

Note

It is absolutely necessary to set the test switch to basic position (position 0) after the test.

5.2 Maintenance

The instrument is maintenance free.

5.3 Repair

Due to safety and guarantee reasons repair work beside the wiring must only be made by VEGA-staff.

In case of a defect please return the appropriate instrument with a short description of the error to our repair department.

5.4 Exchange of electronics

- Loosen the four screws with a screwdriver and open the housing cover.
- Remove the old electronics and plug in the new oscillator.
- Carry out an adjustment. The instruction is given under "4.2 Switch point adjustment".

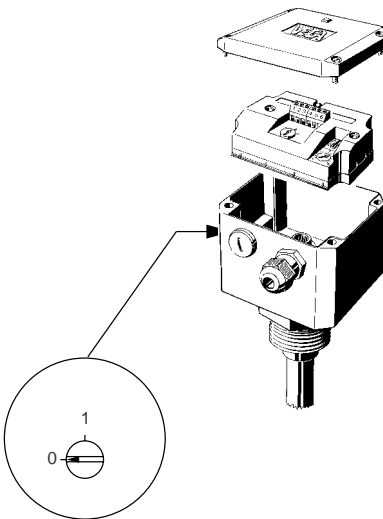

5.5 Failure removal

Failure

No or defective switching function

Measure, failure removal

Note with Ex-systems that the Ex-protection is not influenced by the meas. instruments.

Check the following failure reasons:

- shortcircuit
- sensor not correctly connected
- sensor line interrupted
- supply voltage too low

Push the A/B-switch on the oscillator. The relay output of VEGACAP switches and the control lamp (LED) changes condition. When the relay output does not switch, the sensor or the oscillator is defect.

C_T - Test capacitor
 C_M - Meas. capacitor
 C_K - Compensation capacitor

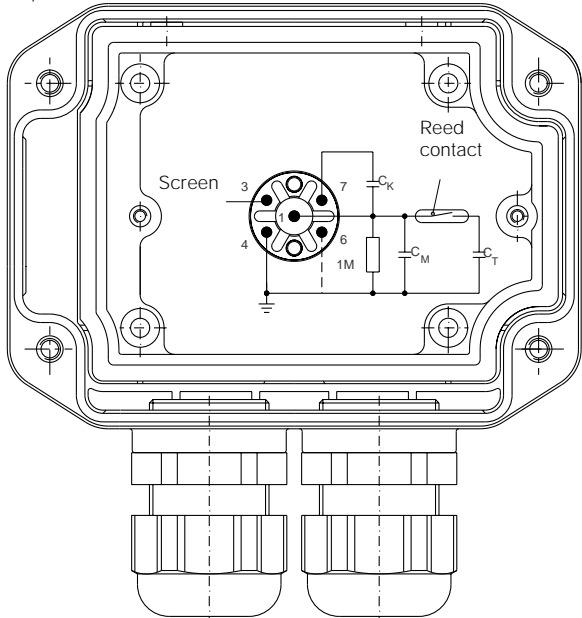

Check the internal connections:

- Remove the housing cover.
- Loosen the three screws with a screwdriver and remove the oscillator out of the housing. With flat pliers you can easily remove the oscillator out of the housing. Hold the oscillator on the extension of the separating wall between the sensor connections.
- Measure with an ohmmeter (range $M\Omega$) the resistance values between the following contacts:

Contact 4 against middle pin (1)

The resistance must be $1\text{ M}\Omega$.

If the resistance is less, this means humidity in the housing or a failure in the electrode isolation. A possible reason could be a not isolated electrode which is used in conductive (humid) product.

If the resistance is higher or if the connection is interrupted, the reason is mainly a bonding failure in the adapter plate or a defect resistor due to strong electrostatic discharge.

In both cases the electrode must be repaired at VEGA.

Contact 4 against vessel

The connection between contact 4 and the metal vessel (not instrument hexagon or electrode flange) should be as good as possible. Measure with an ohmmeter (range very low) the resistance value between contact 4 and the vessel.

- Shortcircuit ($0 \dots 3\ \Omega$), optimum connection
- Resistance $> 3\ \Omega$
 - corrosion on the mounting boss or flange
 - probably the mounting boss was covered with Teflon tape or similar

Check the connection to the vessel. If there is no connection, you can connect a line from the earth terminal outside to the vessel.

Note that coated flanges must be in any case connected via the earth terminal to the vessel.

Contact 7 against middle pin (1)

The resistance must be infinite ($>10\text{ M}\Omega$).

If the resistance is less, humidity penetrated or the compensation capacitor is defect.

Contact 3 against 4

On electrodes without screen the resistance is infinite ($>10\text{ M}\Omega$). On VEGACAP 26, 27, 35 and 98 the resistance must be $1\text{ M}\Omega$. In case of lower values, the electrode isolation is defect or humidity penetrated into the instrument housing.

In case of higher values, a bonding failure in the adapter plate is the case or the resistor is defect.

If you cannot detect a failure in the electrode, then exchange the oscillator by the same type (if available) or return the electrode for repair to us.

If the failure does not disappear after inserting the new oscillator, you have to carry out a new adjustment as the oscillators have certain production tolerances.

Note:

Note when positioning the housing cover that the inspection glass is above the control lamp (LED).

HiTECH

Technologies, Inc.

**A TECHNOLOGY FOR
EVERY LEVEL APPLICATION**

***HiTECH* Technologies, Inc.**

301 Oxford Valley Road - Building 505
Yardley, PA 19067-7706

Tel: 215. 321. 6012; Fax: 215. 321. 6067

Tech Support (Toll Free) 866-DrLevel or 888-NIVELCO

Email: info@DrLevel.com or info@hitechtech.com

Web Site: www.DrLevel.com or www.hitechtech.com

