

Thank you for choosing NIVELCO instrument.
We are sure that you will be satisfied throughout its use.

THERMOCONT

TS / TP
TEMPERATURE SENSORS

USER'S MANUAL





NIVELCO

Manufacturer: 
NIVELCO Process Control Co.
H-1043 Budapest, Dugonics u. 11.
Telefon: (36-1) 889-0100 ■ Fax: (36-1) 889-0200
e-mail: sales@nivelco.com ■ www.nivelco.com

1. APPLICATION

Resistance thermometer and thermo-couple are used as sensors of temperature measurement in industrial process control. The sensors are installed in various kinds of mediums (e.g. liquids, gas, fumes) inside pipes, tanks and furnaces.

2. TECHNICAL DATA

Model	Thermo-couples		Resistance thermometers (1xPt 100, 2xPt 100)			
	TS, TS Ex	J (Fe-Cu-Ni) K (NiCr-Ni)	TSP TSP Ex	TPP TPP Ex	TSV TSV Ex	TSG
Sensor	Class of accuracy	1 or 2 EN 60584.1	A or B EN 60751			
	Type	See order code				Single
	Shock resistance	—				EN 60751 4.4.2
	Electrical insulation	Ungrounded				
Housing	Internal protection tube	Carbon steel EN ISO 3506-1:				
	Material	Al alloy less than 6% Mg, EN 1676:1999				
Wetted part	Wire connection	Screw type terminal 0.5...2.5mm ²				
	Material	DIN 1.4571 stainless steel	PFA covered	DIN 1.4571 stainless steel		
General data	Insertion length	60 ... 3000 mm (see order code)				
	Process connection	See order code				
	Temperature range	-50 °C ... +600 °C		-50 °C ... +200 °C		-50 °C ... +600 °C
	Process pressure	20 °C	2.5 MPa	0.1 MPa	20 °C	2.5 MPa
		400 °C	1.6 MPa		400 °C	1.6 MPa
	Delay time	< 3 min		4.5 min	< 3 min < 20 sec	
	Ambient temperature	-20 °C ... +80 °C Ex version see table				
	Electrical protection	Class III.				
	Electrical connection	Normal and EEx ia: M20x1,5 cable gland, cable Ø 7-10 mm EEx d ia: M20x1,5 cable gland, cable Ø 7,5-11,9 mm EEx d: cable Ø 9,5-10 mm				
	Grounding	Screw on outer part of housing				
Ingress protection	IP 65 EN 60529:2001					
Ex protection mark	 II 2 G EEx d IIC T6...T1, 600°C,  II 1 G EEx d ia IIC T6...T1, 600°C,  II 1 G EEx ia IIC T6...T1, 600°C				-	
Intrinsically safe	Intrinsically safe circuit Only for connection to a certified intrinsically safe circuit EEx ia IIC with following maximum values U _i = 30 V I _i = 100 mA P _i ≤ 750 mW The effective internal capacitance: C _i = 0 nF The effective internal inductance: L _i = 0 mH				-	

2.2 ACCESSORIES

- User's Manual
- Warranty
- Declaration of Conformity,
- Sealing

2.1 TEMPERATURE CLASS

Temperature class	T6	T5	T4	T3	T2	T1	600
Max. Ambient temperature	65 °C	70 °C	70 °C	80 °C	80 °C	80 °C	80 °C
Max. Process temperature	85 °C	100 °C	135 °C	200 °C	300 °C	450 °C	600 °C

2.3 ORDER CODE

THERMOCONT T [] [] - [] [] - [] *

Sensor tube	Code
Tube 1.4571	S
Tube 1.4571 +PFA cover	P

Sensor	Code
Fe-CuNi	J
NiCr-Ni	K
Pt 100	P
Pt 100 shock proof	V
Pt 100 fast	G

Process connection	Code
M20 x 1.5	1
1/2" BSP	2
1/2" NPT	3
3/8" BSP	4
DN 40 flange PN 25 ***	5
DN 50 flange PN 25 ***	6
DN 80 flange PN 25 ***	7
DN 100 flange PN 25 ***	8
DN 150 flange PN 25 ***	9

Sensor Pt100	Code
A class single	1
B class single	2
A class twin	4
B class twin	5
B class + 4 wire	6
A class + 4 wire	7

Length	Code
160	1
250	2
400	3
500	4
1000	5
1500	6
2000	7
2500	8
3000	9

Ex marking	Code
EEx ia	7
EEx d ia	8
EEx d	9

Sensor thermo-couple	Code
Class 1 single	1
Class 2 single	2
Class 1 twin	4
Class 2 twin	5

- * Ex marking for Ex version
- ** Different length on request
- *** TS: steel flange
TP: Steel flange with PTFE insert

2.4 DIMENSIONS

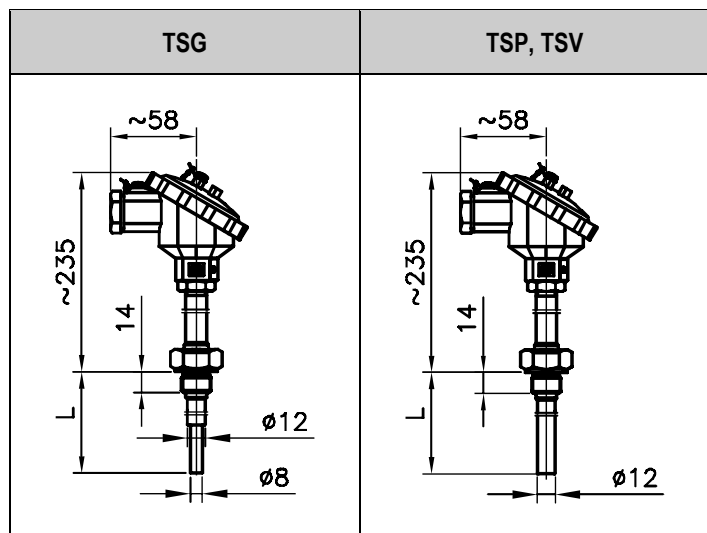

Normal

Normal, EEx ia

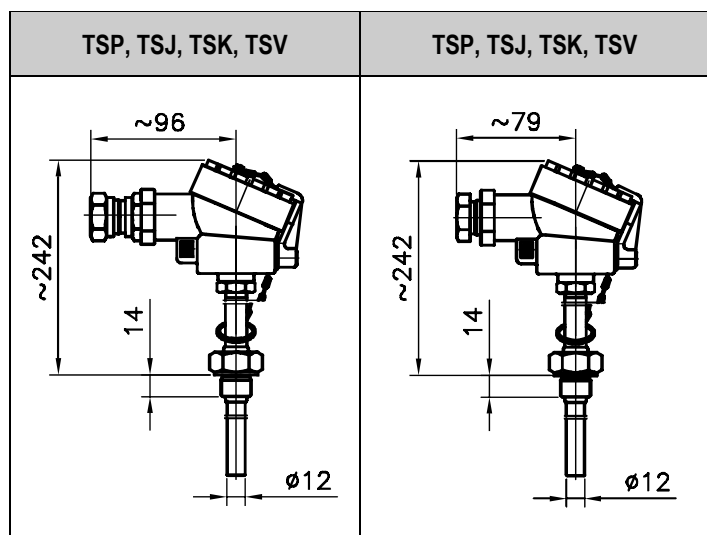

EEx d ia

EEx d

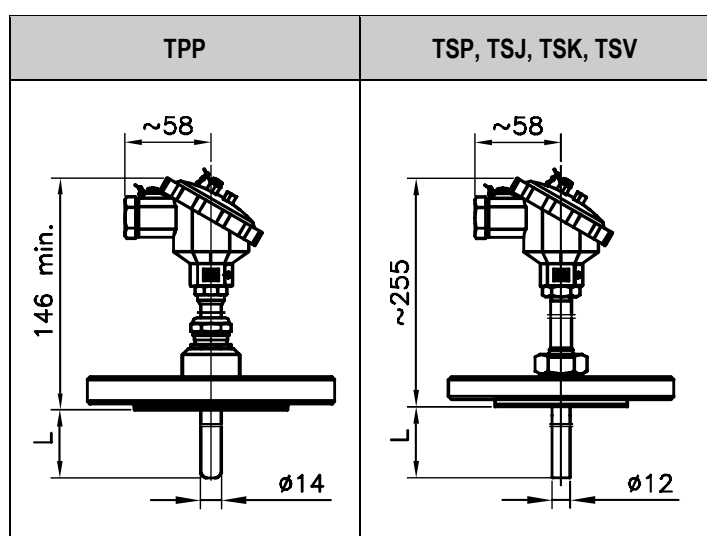

Normal, EEx ia

Normal, EEx ia

3. INSTALLATION

Installation may be done by process connection (including flange) detailed in Technical Data and figures. The device should be handled with care to avoid damage or bend of the protection tube during transportation and installation.

4. ELECTRICAL CONNECTION

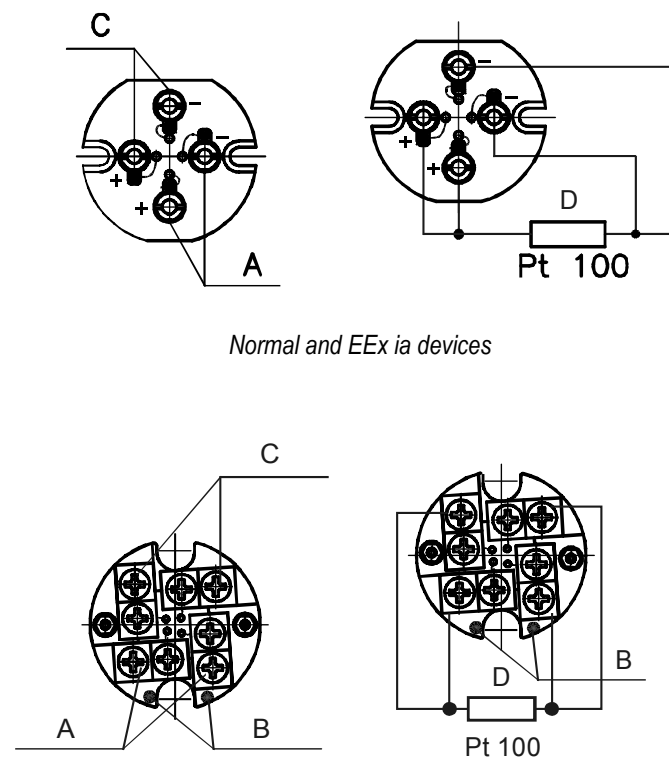

Normal and EEx ia devices

EEx d, EEx d ia devices

LEGEND:

- A: Pt 100 or thermocouple No 1.
- B: Marking
- C: Pt 100 or thermocouple No 2.
- D: 4 wire system

Four wire system is requiring parallel connection of marked and not marked points of wire terminal to the Pt sensor. Thermocouple + end connection is according to the (+) or (-) point.

4.1 SPECIAL CONDITIONS OF EX VERSION

The place and mode of installation must guarantee the protection of the apparatus against external mechanical effects during operation and service.

The explosion proof "d" type temperature sensors must be used only with the certified cable gland.

In case the variation with the PFA coated protrusion pipe is applied, the flow rate of the medium shall be determined so – considering the parameters of the medium and the geometrical features – that static charge could be avoided.

Heat resistance of the cable insulation must meet the highest value (80 °C) of the ambient temperature allowed at the place of application.

5. MAINTENANCE, REPAIR

The instrument does not require regular maintenance. Repairs during or beyond guarantee period are carried out solely by the manufacturer.

6. STORAGE CONDITIONS

Environment temperature -25 °C ... +55 °C.

7. WARRANTY

All NIVELCO products are warranted to be free from defects according to the Warranty Sheet, within two (2) years from the date of purchase.

tsp1210a0600h_08
Sept., 2006.

Nivelco reserves the right to change technical specification without notice.