

HiTECH

Technologies, Inc.

NivoSwitch™ Intelligent SHORTIE Level Switch

Intelligent Vibration Sensing Technology

Series RCP-400

*combines frequency & amplitude sensing
for delivering unprecedented performance*

IDEAL for

- ◆ Chemicals
- ◆ Food & Beverages
- ◆ OEM's
- ◆ Plastics
- ◆ Power Generation
- ◆ Petrochemicals
- ◆ Pulp & Paper
- ◆ Water Treatment

ADVANTAGES

Easy Installation

Maintenance Free

Fine Polished Sensor

Standard 1" NPT Mounting

Status Indication (Bi-color LED)

Dielectric Change Insensitive

Compact Rugged Construction



The **HiTECH Intelligent NivoSwitch™** is a mechanical resonance system; excited, and kept in resonance by electronic circuitry.

When the material level reaches the vibrating tines, it changes the vibration. This change is sensed by the electronic circuit; which activates the output.

Unaffected by viscosity, foam, conductivity, dielectric, suspended solids, bubbles and/or turbulence, the **NivoSwitch™** is ideal for a variety of liquid or free flowing granules or powder level applications, including: run-dry protection, vessel overflow, and fill/dump control.



HiTECH Technologies, Inc.

301 Oxford Valley Road, Yardley, PA 19067-7706

Technical support: 800. 755. 4507

Tel: 215. 321. 6012 ~ Fax: 215. 321. 6067 ~ www.hitechtech.com

HiTECH

Technologies, Inc.

NivoSwitch™ Intelligent SHORTIE Level Switch

Series RCP-400

SPECIFICATIONS

Type Vibration Sensing Technology point level switch	Outputs Available Two Wire AC Serial connection w/load 20 to 255 VAC 50/60HZ Two Wire DC 9 ± 1 ma free 14 ± 1 ma immersed Supply 24 VDC	Sensor 316 Stainless Steel 1" NPT mounting
Repeatability ±0.04 inches	Three Wire DC PNP/NPN (350 ma @ 55V) Supply ~ 12 to 55 VDC	Temperature Liquid -40 to +266 °F Ambient -40 to +158 °F
Response Time When immersed 0.5 secs. When free < 1 sec.		Pressure Up to 362 psi (2.5 MPa)
Output Mode Indicator Bi-color LED		Function Test Test magnet (optional)

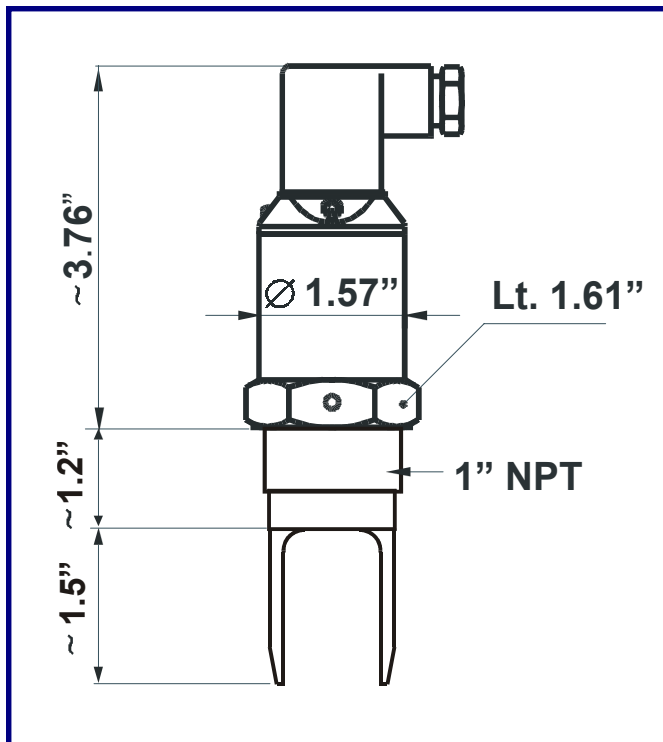

PERFORMANCE GUARANTEE

Since 1986, every instrument sold by **HiTECH** has been guaranteed to perform in the application it originally was engineered and recommended for. Our company policy remains the same, every product sold comes with a **written performance guarantee**.

Should the equipment be unable to perform satisfactorily in your application and we are not able to correct the problem, we will accept the instrument in return and issue full credit.

This performance guarantee is valid for 60 days. Thereafter, our standard limited two years factory warranty goes into effect.

Copyright HiTECH Technologies, Inc.2002

HiTECH Technologies, Inc.

301 Oxford Valley Road, Yardley, PA 19067-7706

Technical support: 800. 755. 4507

Tel: 215. 321. 6012 Fax: 215. 321. 6067 www.hitechtech.com