

**NIVOCAP Cxx-100 SERIES
CAPACITANCE TWO-WIRE
LEVEL TRANSMITTER**



***HiTECH* Technologies, Inc.**

301 Oxford Valley Road - Building 505A - Yardley, PA 19067-7706

Tel: 215. 321. 6012; Fax: 215. 321. 6067

Tech Support (Toll Free) 866-DrLevel or 888-NIVELCO

Email: info@DrLevel.com or info@hitechtech.com

Web Site: www.DrLevel.com or www.hitechtech.com

1. TECHNICAL DATA

Unit type	Rod probe		Light cable probe		Heavy duty cable probe	
	C..R-100 C..S-100	C..P-100 C..T-100	C..K-100 C..V-100	C..L-100 C..W-100	C..N-100	C..M-100
Probe type	Insulated	Partially insulated	Insulated	Partially insulated	Insulated	Partially insulated
Probe length	0.2 to 3 m		1 to 20 m			
Material of wetted parts	SS316Ti					
Connection Probe	Steel	SS316Ti	Steel	S316S31	Steel	S316S31
Insulation	PFA	-	FEP	-	PE	-
Mechanical strength	-	-	5 kN	5 kN	45 kN	35 kN
Capacity of insulated probe	≈600 pF/m	-	≈200 pF/m	-	≈1500 pF/m	-
Medium temperature	CT/CN: -13 °F to 248 °F (-25 to +120°C); CH/CL: -13 °F to 392 °F (-25 to +200°C)			-13 °F to 176 °F (-25 to +80°C)		
Medium pressure	max. 16 bar @ 392 °F (200°C)					
Ambient temperature	-13 °F to 185 °F (-25 to +85°C)					
Output	4 to 20 mA					
Capacitance ranges	200 pF / 1 nF / 5 nF; selectable					
ZERO setting (4 mA)	0 to 80% of measuring range					
SPAN setting (20 mA)	20 to 100% of measuring range					
Measuring frequency	25 kHz					
Supply voltage	U _S = 12...30 V DC, max. 25 mA					
Maximum load resistance	$R_L = \frac{U_S - 12V}{0.02A}$					
Non-linearity	<0,5%					
Temp. Coeff. of ZERO	2 µA/°C					
Temp. Coeff. of SPAN	3 µA/°C					
Electric connection	Pg16 for Ø8 to 15 mm cables; with 0.75 to 2.5mm ² wire cross section					
Enclosure	IP65					
Electrical protection	normal vers.	Class III.				
Ex protection mark	Intrinsically safe					-
Ex protection mark	CT: EEx ia/ib IIB T4, issued: TÜV-A Nr.96.C.003X					
Mass	0.4 kg + 0.1 kg/10cm		0.4 kg + 0.15 kg/m		0.4 kg + 0.8 kg/m	

Note: The 4 mA output current is scaled to the 0.2-fold value of the 1 nF range, whereas the 20 mA output current is scaled to the nominal length of the unit.

2. ACCESSORIES

- User's Manual
- 1pc. Plug-in type screw terminal

3. OPERATION

The capacitance probe constitutes a capacitor together with the electrically conducting tank or the auxiliary probe. Any changes exhibited by the current generated by the measuring voltage and flowing through this capacitor are proportional to the level variations of the substance between the electrodes.

4. INSTALLATION

Mounting:

The probe must be mounted in parallel with the reference electrode (tank wall, reference probe). Cable probes must either be attached to the tank bottom by the attachment facility provided on the rope end; or, by a weight.

Good practice is to locate probes away from the area where mechanical force from the process is most intense.

In case a tank may be subject to significant mechanical vibrations, provision should be made for the mechanical damping (insertion of a rubber washer, for example).

Reference probe:

As a reference probe, an insulated or un-insulated probe can be used, placed parallel to the measuring probe in a close distance.

In case of tanks with spherical sides (lying cylindrical tanks), or where the tank wall can not be used as a reference probe, a pipe around the measuring probe is recommended to be used as a reference probe. The inner diameter for the reference tube (probe) should be selected to be a value in the 36 to 500 mm range, depending upon the viscosity and the dielectric constant of the process medium.

5. DIMENSIONS

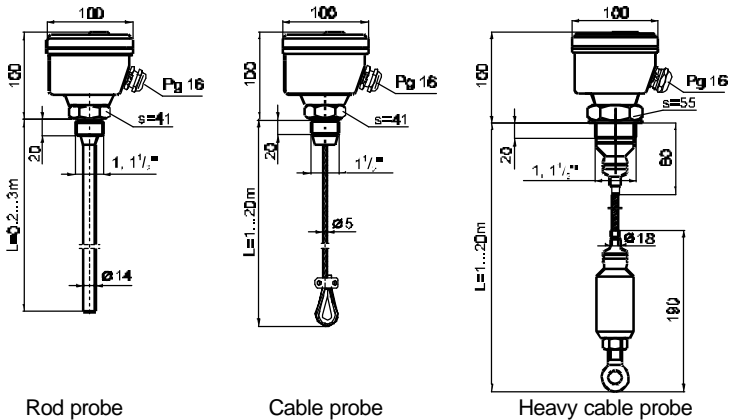

Fig. 1 Outline drawings

Type code	Process connection	Type code	Process connection
CTR/CHR CTP/CHP	1" BSP	CNR/CLR CNP/CLP	1" NPT
CTS/CHS CTP/CTT	1 1/2" BSP	CNS/CLS CNP/CLT	1 1/2" NPT

6. WIRING

Remove housing cover and connect device to current loop. Make sure to carry out the wiring with correct polarity.

The probe must be electrically connected to the reference probe !

Connect reference probe to grounding screw on the outside of housing. Using the tank as a reference probe, electrical connection between device and reference probe is maintained via the process connection.

In Ex applications, either use an intrinsically safe supply unit, or insert a Zener-barrier between an ordinary supply unit and the device.

Recommended Zener-barrier:

Type	Manufacturer
728	MTL
8901/31-280/075/00	Stahl
Recommended isolated server unit:	
4041	MTL

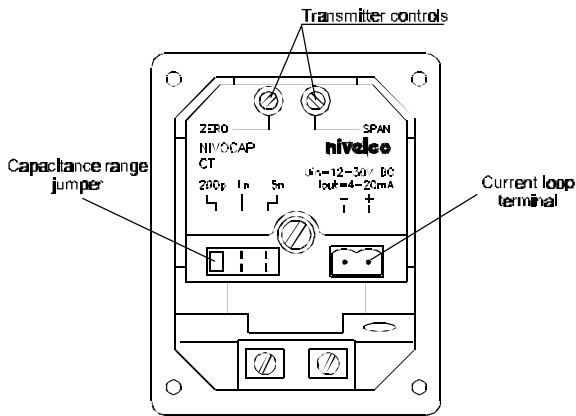

Fig. 2
Probe housing with removed cover

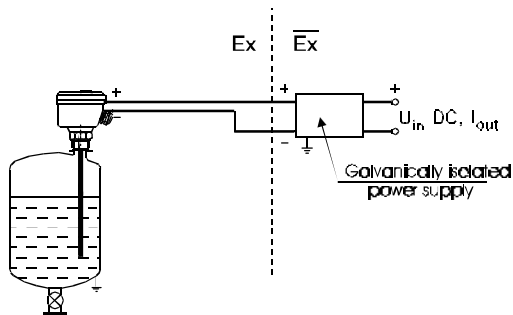

Fig. 3
Ex installation

In case of measuring potentially explosive materials, only partially insulated probes can be applied without any limitation. The insulated probes are only applicable for level measurements on process media that are capable, in the possible event of the probe insulation getting electrically charged, of leading away the charges, i.e. that have specific resistance under 10^4 Ohmmeter.

7. CALIBRATION

1. Setting the "CAPACITANCE RANGE" jumper

In case of conducting medium:

Only insulated probes can be used.

The overall capacitance of the system depends practically only on the insulation of the probe.

By knowing the length of the probe and its "capacitance per meter" value (see Technical Data table), the overall capacitance can be calculated and the Jumper can be set accordingly.

Overall capacitance (C)=

Probe length * Capacity of insulated probe per meter

Example: 2 m rod probe:

$C = 2 \text{ m} * 600 \text{ pF/m} = 1200 \text{ pF} = 1,2 \text{ nF}$

Select "5nF" measuring range with the jumper

In case of non conducting medium:

Always use a reference probe placed as close to the capacitance probe as possible. A coaxial reference probe provides the best sensitivity.

The overall capacitance of the system depends largely on the relative dielectric constant (ϵ_r) of the measured medium and the distance between the capacitance probe and the reference probe.

Overall capacitance = Base capacitance (see Fig. 4.) * relative dielectric constant (ϵ_r) of the measured medium

$$C = \epsilon_r * C_0$$

Example: 10 m light cable probe used with a \varnothing 100 mm coaxial reference electrode on heating oil:

Relative dielectric constant (ϵ_r) of heating oil: 2.1

Base capacitance (C_0)= 180 pF (see Fig. 4.)

$$C = 2.1 * 180 \text{ pF} = 378 \text{ pF}$$

Select "1nF" measuring range with the jumper

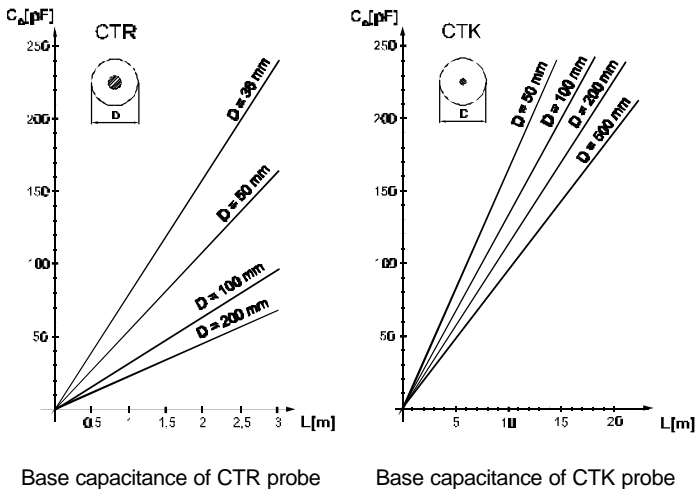

*Fig. 4
Base capacitance*

The overall capacitance can typically only be calculated roughly, the best is to set the jumper to the center position (1 nF) prior to starting the 4-20 mA calibration.

2. Fill up tank to the required 4 mA (Low) level, insure that capacitance probe is in contact with the measured material.
3. Bring the multi-turn potentiometer "SPAN" approximately into its middle position.
4. Set 4 mA by the "ZERO" potentiometer.
5. Fill up tank to the required 20 mA (High) level.
6. Set 20 mA by the "SPAN" potentiometer.
7. The adjustment is considered as satisfactory if the active part of the probe (i.e. the length of the probe section between the calibrated 4 and 20 mA points) is not shorter than 0.3 times the overall probe length.

8. MAINTENANCE, REPAIR

The device does not require routine maintenance. In some instances, however, the sensor may need occasional cleaning to remove surface deposits

9. STORAGE CONDITIONS

Environment temperature: -13 °F to + 140 °F (-25 °C to +60 °C)
Relative humidity: up to 98 %

10. PERFORMANCE GUARANTEE

Since 1986, every instrument sold by **HITECH** has been guaranteed to perform in the application it originally was engineered and recommended for. Our company policy remains the same; every product sold comes with a **written performance guarantee**.

Should the equipment be unable to perform satisfactorily in your application and we are not able to correct the problem, we will accept the instrument in return and issue full credit.

This performance guarantee is valid for 60 days. Thereafter, our standard limited two years factory warranty goes into effect.

HITECH Technologies, Inc.

301 Oxford Valley Road - Building 505A - Yardley, PA 19067-7706

Tel: 215. 321. 6012; Fax: 215. 321. 6067

Tech Support (Toll Free) 866-DrLevel or 888-NIVELCO

Email: info@DrLevel.com or info@hitechtech.com

Web Site: www.DrLevel.com or www.hitechtech.com