

HiTECH

Technologies, Inc.

NIVOSWITCH CIP

Clean In Place Point Level

Unique Vibration Sensing Technology

Model RGR-300

*combines frequency & amplitude sensing
for delivering unprecedented performance*

IDEAL for

- ◆ **Bottling Plants**
- ◆ **Breweries**
- ◆ **Dairies**
- ◆ **Food Processors**
- ◆ **Pharmaceutical Plants**
- ◆ **OEM s**
 - filling machines
 - small tanks
 - hoppers

ADVANTAGES

2" Tri-Clamp Mounting
(Designed to 3-A sanitary standards)
No moving parts
Easy to install
Maintenance free
Insensitive to dielectric changes
For liquids & free flowing solids
Fine polished sensing probe
Intrinsically safe
(EEx ia) & WHG approvals
Field status indication (Bi-color LED)



Difficult applications that were previously not possible from tuning fork technology are now a reality with the unique signal processing incorporated in the NIVOSWITCH.

Combining frequency and amplitude sensing, an unprecedented performance is achieved.

Applications involving sanitary food, beverage or pharmaceutical products, vibrating vessels, turbulent liquid surfaces, as well as powders or light granules are now routine tasks for the "intelligent" NIVOSWITCH.



HiTECH Technologies, Inc.

301 Oxford Valley Road, Yardley, PA 19067-7706

Technical support: 800. 755. 4507

Tel: 215. 321. 6012 ~ Fax: 215. 321. 6067 ~ www.hitechtech.com

SPECIFICATIONS

<p>Type Vibration Sensing Technology point level switch</p> <p>Repeatability $\pm 0.04''$</p> <p>Response Time When immersed 0.5 secs. When free < 1 sec. (low sens.) < 3 sec. (high sens.)</p> <p>Material Density Liquids > 43.7 lb/cu-ft Solids > 0.62 lb/cu-ft</p>	<p>Outputs Available Two wire AC serial connection w/load 20 to 255 VAC 50/60HZ</p> <p>Relay output SPDT - 8 amp, 250 VAC supply ~ 20 to 50 VDC or 20 to 255 VAC 50/60HZ</p> <p>3 wire DC PNP/NPN (350 ma @ 55V) supply ~ 12 to 55 VDC</p> <p>2 wire DC (24 VDC supply) Immersed 14 ± 1 ma Free 9 ± 1 ma</p>	<p>Sensor 316 Stainless Steel</p> <p>Mounting 2" Tri-Clamp Sanitary (Clean In Place)</p> <p>Cable Length 12 inches Standard Other lengths available</p> <p>Temperature Medium -40 °F to +266 °F</p> <p>Pressure Up to 362 psi (2.5 MPa)</p>
---	---	--

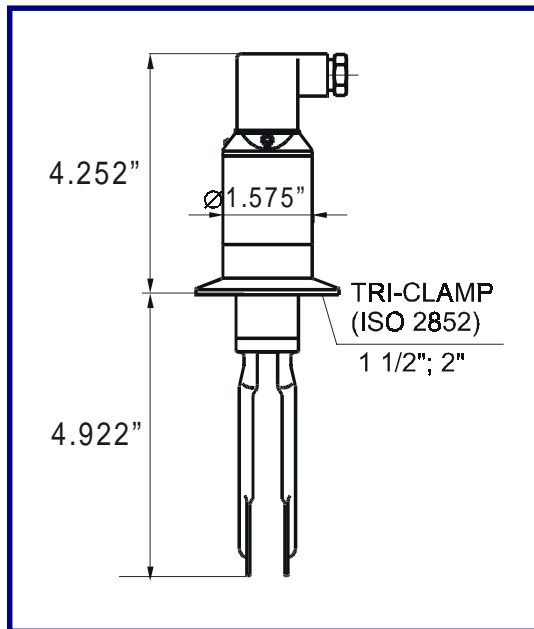

PERFORMANCE GUARANTEE

Since 1986, every instrument sold by **HITECH** has been guaranteed to perform in the application it originally was engineered and recommended for. Our company policy remains the same, every product sold comes with a **written performance guarantee**.

Should the equipment be unable to perform satisfactorily in your application and we are not able to correct the problem, we will accept the instrument in return and issue full credit.

This performance guarantee is valid for 60 days. Thereafter, our standard limited two years factory warranty goes into effect.