

HiTECH

Technologies, Inc.

MICROSONAR

U-200 SERIES

Ultrasonic Proximity Sensor

INSTRUCTION MANUAL



***HiTECH* Technologies Inc.**

301 Oxford Valley Road
Yardley, PA 19067-7706

Tel: 215. 321. 6012 - Fax: 215. 321. 6067

Technical support: 800.755. 4507 or 888. NIVELCO

Email: info@hitechtech.com

1. Operation

The HiTECH/NIVELCO MICROSONAR proximity sensor, working on the ultrasound echo principle is suitable for detection of the position or measuring distance of objects.

The measurement can only be accomplished if the space between the unit and the target is free of any obstacles for making the way of the ultrasound beam and good reflection on the target.

The output of the unit is either PNP switch or analog signal of voltage or current..

2. Technical data

General Data

Type		UR□-213	UT□-211	UT□-212	URP-263	UTP-261	UTP-262
Nominal range	X _{min}	8" (0.2 m)			16" (0.4 m)		
	X _{max}	39" (1.0 m)			20' (6.0 m)		
Ultrasound frequency		160 kHz			60 kHz		
Total beam angle		5°					
Meas. sequence time (Tp)		25 ms			80 ms		
Resolution		0.1 mm	0.25 mm	0.25 mm	0.1 mm	1.5 mm	1.5 mm
Output		PNP switch	4 ... 20 mA	0 ... 10 V	PNP switch	4 ... 20 mA	0 ... 10 V
Programming		With contacting a PRG cable, with magnet.					
Ambient temperature		-4 °F ... +155 °F (-20 ... +70 °C)					
Power supply		10.8 ... 30 V DC					
Consumption Us=12 V		< 31 mA*	< 55 mA	< 41 mA	< 30 mA*	< 54 mA	< 40 mA
Consumption Us=24 V		< 39 mA*	< 63 mA	< 49 mA	< 37 mA*	< 61 mA	< 47 mA
Input protection		Reverse polarity, surge, ESD					
Integrated cable		Shielded cable with PVC coating L = 10 feet					
Cable core		4 x 0.5 mm ²					
Electric protection		Class III					
Ingress protection		U□S-2□□ IP 67, U□P-2□□ IP68				IP 68	
Enclosure		U□S-2□□: stainless steel with PP covers, U□P-2□□: PP			PP (molded with resin)		
Weight		400 g				530 g	

Output Data

TYPE	UR□-2□3-4	UT□-2□2-4	UT□-2□1-4
Output			
Rating	Max. 30 V DC	-	-
Rating	Max. 200 mA	-	-
Voltage residuum	< 2.5 V	-	-
Switching delay or Settling time Tb* =a** Tp	25, 100, 200, 400 ms with U□□-21□-4		
	80, 320, 640, 1280 ms with U□□-26□-4		
Temperature coeff.	± 0,02% / C		
Linearity	-	± 0,35%	
Repeatability	1 mm	1,5 mm	1.5 mm
Output signal	-	0 ... 10 V (Us > 13 V)	4...20 mA
Load resistance	-	≥ 1 kΩ	≤ 500 Ω (Us > 14 V)
Output protection	Short circuit, EMC	Short circuit, EMC	EMC

3. Dimensions

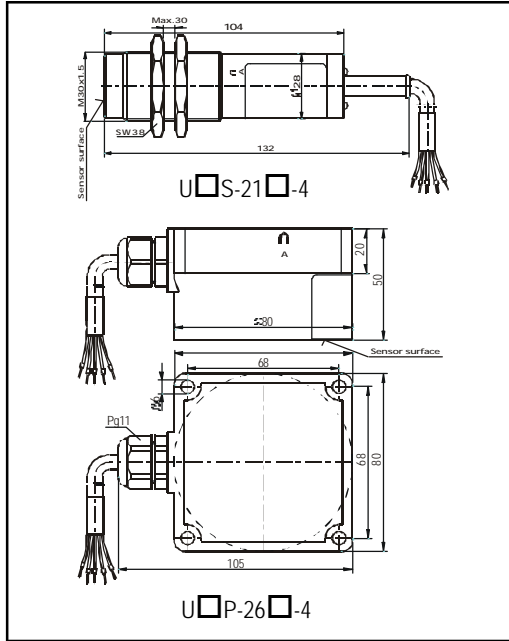

4. Installation

The unit should be installed stable and to a place without vibration.

Pipe-enclosure units should be fixed to a mounting plate with a hole of $\varnothing 31$ mm by the help of the nuts supplied. Units with flat enclosure can be mounted to the wall or any flat surface with four bolts. Cables should be fixed near to the enclosure and LEDs should have to be visible.

In case of limited space, the way of the ultra sound path may be broken by a metal sheet as below (Figure1).

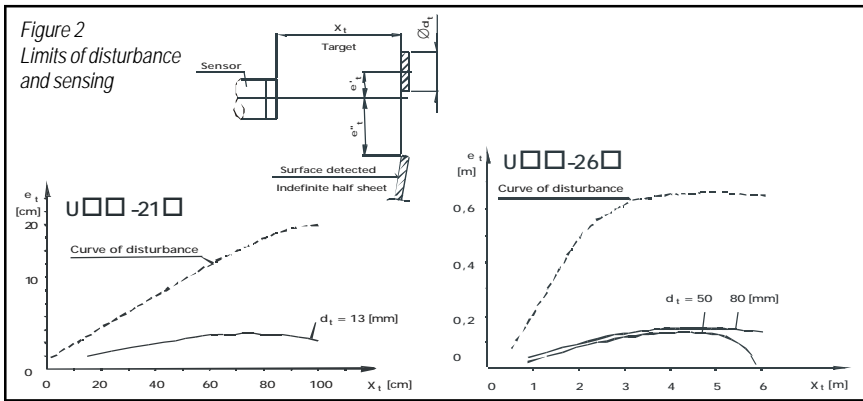
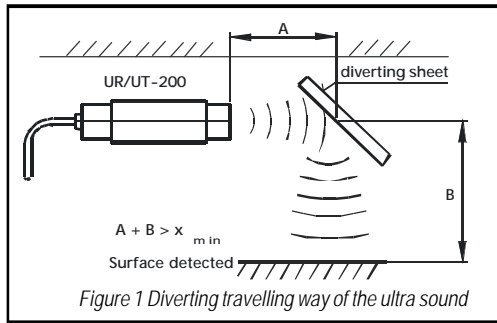

4. Installation (continued)

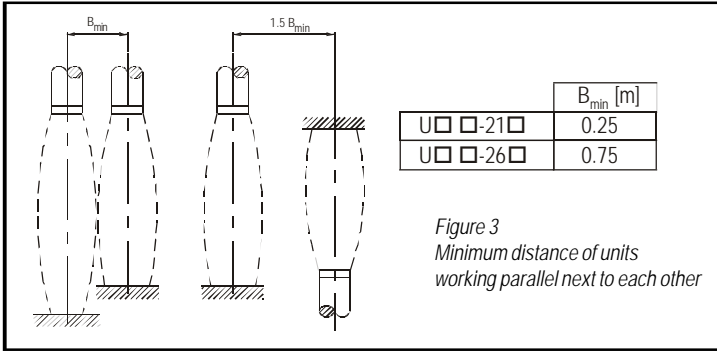

Figure 3
Minimum distance of units working parallel next to each other

Figure 2 is indicating distances (e'') within which the unit is sensing the target as well as distances (e'') outside of which disturbing objects (indefinite half-sheet) is not disturbing operation of the unit. Units with the same frequency may mutually disturb each other as sent or reflected ultrasound may reach the other unit. To avoid such interference, units with parallel axis should be installed outside of the minimum distances as per Figure 3. Applications of targets with round reflecting surfaces (like pipes) that involve side reflections greater minimum distances might be required.

5. Wiring

Wiring should be carried out in accordance with Figure 4 and Figure 5 taking into consideration color of the wires as per Table 1.

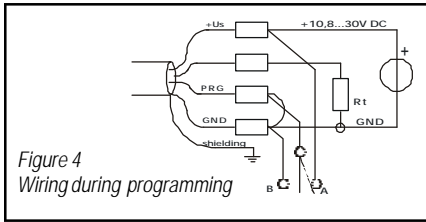

Figure 4
Wiring during programming

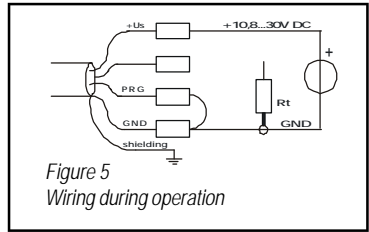

Figure 5
Wiring during operation

Table 1 Cable colors

Type	Cable	Color
UR□-2□3-4	+U _s	brown
	SW	green (black)
	PRG	white
	GND	yellow
	shielding	blue
UT□-2□1-4 UT□-2□2-4	+U _s	brown
	I _{out} or U _{out}	green (black)
	PRG	white
	GND	yellow
	shielding	blue

6. Start Up, Operation and Programming

6.1 START UP, OPERATION - Following the power up, the unit will run a self-test routine for 5 seconds. During the self-test all three LEDs are lit. In case of revealing a failure LEDs will blink in the same rhythm. Interpretation of the LED states during proper operation:

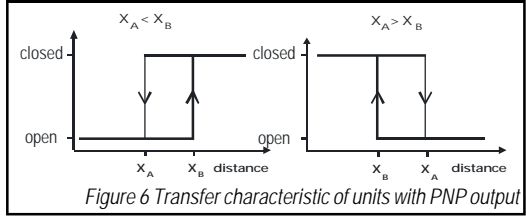

- Green:** Blinking in the rhythm of the measurement.
- Yellow:** Lit continuously in case of valid echo.
- Red:** Lit if the unit is sensing an object within the minimum measuring range.
Error will be indicated by the output

SWITCHES compare measured distance with the two (X_A and X_B) distances and switch in accordance with Figure 6. TRANSMITTER output signal is (within the two distances programmed) proportional to the distance in accordance with Figures 7 and 8.

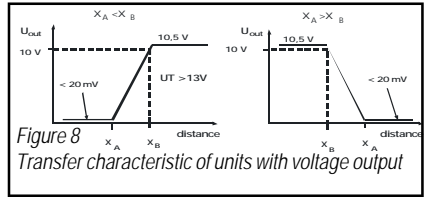
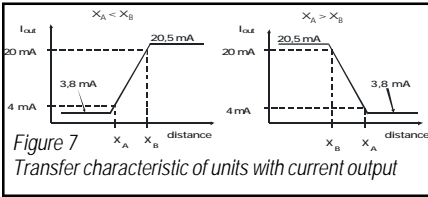

After the first power up the unit will work with the following Factory Setting and characteristic:

SWITCHES: $X_A = X_{max} / 2, X_B = X_A + 0.1 m$

TRANSMITTERS: $X_A = X_{min}, X_B = X_{max}$

Distance parameters X_A and X_B can be changed with programming by placing a good reflecting target at the distance to be programmed and by stepping to the relevant Menu Point. The unit will measure and store (learn) the distance.

MICROSONAR will accept the echo coming from the reflecting surface (within the range) nearest to the unit. The range of the unit with Factory Setting extends between X_{min} and X_{max} . (Nominal range)

If the target is moving within narrower range it is advised to reduce the range by far-end blocking which should be done with programming X_T .

Factory default $X_T = X_{max}$

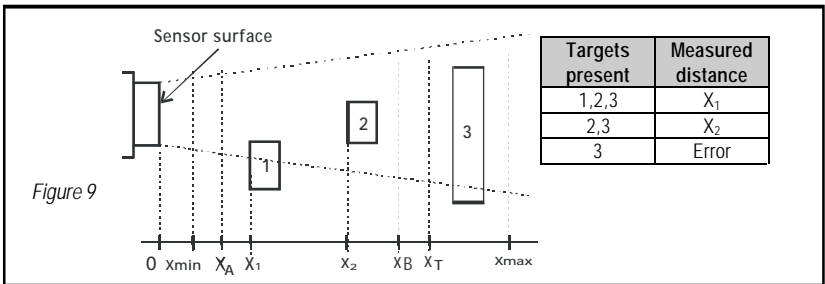

Far-end blocking will prevent evaluation of echoes coming behind X_T . Should for any reason (unstable echo, intensive movement of air) the echo be lost, the object behind X_T will not be taken into consideration but lack of the valid echo will immediately trigger error indication.

Error indication on the output:

SWITCH STATUS: off (open)

TRANSMITTER $I_{OUT} = 3.6 \text{ mA}$

TRANSMITTER $U_{OUT} = 0 \text{ V}$

The signal processing of the unit can be adapted for the most different requirements and conditions of the application. The two programmable parameters influencing signal processing are the averaging number and the number of discarded echoes.

Averaging number: **a** (1, 4, 8 or 16)

To avoid mistaken measurements the unit will not provide output on the basis of a single measurement but by taking the average of the last **a** number of distance samples.

Increasing averaging number will reduce small oscillation of the output signal born by the indefinite movement of the target or measurement error (caused by noise). On the other hand this will cause a target tracking failure depending on the speed of the target which will be mended after a $T_b = a \cdot T_p$, settling time or switching delay

Number of discarded echoes: **k** (1, 3, 5 or 10)

Under disadvantageous conditions (air movement, not perpendicular or bad reflecting surface) some of the echoes may miss the sensor. Giving immediate attention to this, might lead to frequent error indication or measurement failures. Therefore the unit would check the measured distance for verifying that it is within the range.

Measured distance outside the range will be disregarded while calculating the average and leaves output signal unchanged. The unit can disregard **k** number of consecutive distance samples. After that error will be indicated.

If due to bad reflection substantial number of echoes go astray and the number of invalid (incorrect) echoes, between two valid ones, is smaller than **k** the unit will work continuously i.e. without indicating error. The greater the value of **k** programmed, the less sensitive the unit to invalid echoes but the reaction time for indication of error will increase. To maintain continuous operation the programmed range is advised to keep as narrow as possible.

The greater the speed of the target the smaller should the averaging number be chosen. The worse the reflection of the target the higher value should be chosen for **k** (number of discarded echoes).

6.2 PROGRAMMING

1. Touch-Magnet Programming

The magnetic screwdriver (with its cap removed) should be put to the points on the enclosure marked up with **A** or **B** according to Figure 10. These steps will follow below as steps **A** or **B**.

Touch-Magnet Programming is only available if it is not disabled and the PRG wire is free. Disabling can be programmed both by Touch-Magnet Programming or by cable contacting, but it can only be released by cable contacting.

2. Programming with cable contact

The steps **A** or **B** will be represented by connecting wire PRG with $+U_s$ or GND respectively.

These connections can be established by the use of switch or push buttons in accordance with Figure 4. or by simply connecting cables.

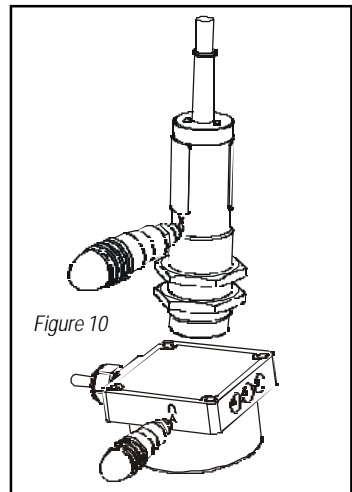

Different states within the programming procedure will be indicated by the three LEDs. Steps **A** and **B** (magnet touch, wire connection) should be maintained till the effect will be indicated by the relevant change of the LED status.

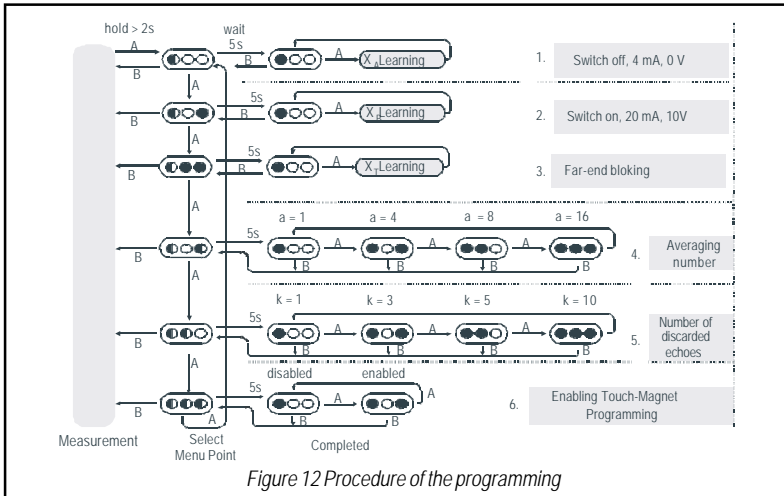
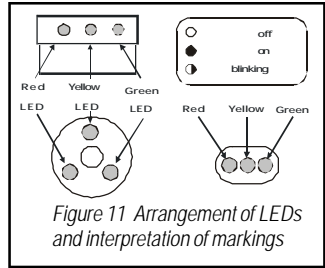

For entering programming mode: step **A** for 2 s
 For quitting programming mode: step **B**
 Programming mode entered: is indicated by blinking red and going off yellow and green LED s.
 While in programming mode (with red LED blinking) every step **A** will change the Menu Points. The six different Menu Points are indicated by combination of states of yellow and green LEDs.

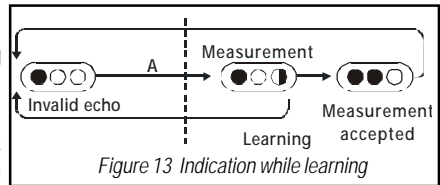

Selecting the Menu Point the unit will after 5 s automatically (without step **A** or **B**) be ready for programming, which will be indicated by the red LED. In the first four Menu Points learning should be initiated by step **A**. Blinking of the green LED indicates the measurement during the learning. On getting a valid echo the yellow LED will lit and the relevant numeric value of the measured distance appears on the output (for instance with measured distance of 0.4 m the output will be 0.4 mA or 0.4 V!) With repeated step **A** new distance can be learned and the old one will be overwritten. Step **B** finalizes learning and results in return to Menu Point. Step **B** represents quitting Programming Mode. Parameters **a** and **k** can be programmed in Menu Points 4 and 5
 Touch-Magnet programming is enabled or disabled in Menu Point 6 by step **A**. Disabling of the Magnet-Touch Programming by use of the magnet is completed after quitting Programming Mode. During Touch-Magnet Programming the Wire-Contact Programming is disabled and vice versa. If the unit is left in Programming Mode by mistake it will automatically quit after 10 seconds.

If the unit will be powered up with PRG wire connected to +Us the factory setting will automatically be reloaded.

Example: assignment of X_B

Place a target in a distance (X_B) from the unit to which you want to assign 20 mA or 10 V or triggering switch-on. In the learning procedure distance of X_T will be disregarded.

Put the magnet to point **A** till the red LED will begin to blink (entering first Menu Point in the Programming Mode). Remove the magnet and put it again to point **A** to step into the second Menu Point. The red LED will be blinking, the yellow one will go off and the green one go on (second Menu Point entered). Remove the magnet and wait (approximately 5s) until the red LED begins to blink. (ready for learning). Put the magnet again to point **A** (learning started). Green LED starts to blink (representing measurement) then goes off (measurement completed) yellow LED will lit for short (valid echo). Learning has been completed if the red and yellow is on and green is off. Put, remove and put again the magnet to point **B** to quit Menu Point and Programming Mode respectively.

7. Maintenance and Repair

The unit does not require maintenance on a regular basis. In some very rare instances however, the transducer may need a cleaning from deposited material. This must be carried out gently, without scratching or pressing the surface of the transducer.

Repairs during or after the warranty period are carried out exclusively at the Manufacturers. Equipment sent back for repair should be cleaned or neutralised (disinfected) by the User.

8. Storage

Ambient temperature: -20...+70 °C

Relative humidity: max. 98%

9. Warranty

HiTECH provides warranty for the period of 2 (two) years.

All repairs under guarantee are performed in the Manufacturer's premises.

Cost of dismantling, reinstalling and transport are borne by the Customer.

Claims for guarantee are not valid in respect of damages during transportation, failures due to abnormal usage, breakage, disaster, or incompetent installation or operation.

HiTECH
Technologies, Inc.

301 Oxford Valley Road - Yardley, PA 19067-7706

Tel: 215. 321. 6012 - Fax: 215. 321. 6067

Toll Free: 800.755. 4507 or 866. DrLevel

Email: info@hitechtech.com

www.DrLevel.com or www.hitechtech.com