



NIVOPRESS

NPK-100 AND -200 SERIES
HYDROSTATIC PRESSURE
LEVEL TRANSMITTERS



HiTECH Technologies, Inc.

301 Oxford Valley Road - Building 505A - Yardley, PA 19067-7706

Tel: 215. 321. 6012; Fax: 215. 321. 6067

Tech Support (Toll Free) 866-DrLevel or 888-NIVELCO

Email: info@DrLevel.com or info@hitechtech.com

Web Site: www.DrLevel.com or www.hitechtech.com

1. APPLICATION

The NIVOPRESS submersible hydrostatic level transmitter is applicable for level monitoring of clean or mildly contaminated liquids in boreholes, open reservoirs and tanks. The unit is easy to install in existing tanks and in deep boreholes and is especially well suited for controlling submersible pumps.

2. TECHNICAL DATA

Model type		Hydrostatic level transmitter	
		NPK2...	NPK1...
Measuring limit		0-20 m water head	20-200 m water head
Overload		max. 100%	
Output		4 to 20 mA	
Accuracy on full scale		< 0.5%	
Temperature coefficient		± 0.05%/10°C	
Offset error		± 0,1 mA	
Operating voltage		9 to 30 V DC	
Maximum load resistance		$R = \frac{U_i - 9V}{0,02 A}$ Ohm	
Surge protection		30V/600W/1ms	
Mechanical Protection		IP 68	
Operating temperature		-10°C to 60°C	
Material	Probe	Stainless steel	
	Cable	Polyurethane	
Dimensions	Probe	Ø22 x 175 mm	Ø28 x 185 mm
	Cable	Ø 7 mm	

Model type		Over Voltage Protection Unit (OVP)	
		OVP-12/33	OVP-32/33
Mounting		Field	Rail DIN 46277-3
Protection		IP54	IP20
Voltage clipping		Slow: 90 V _{pp} , fast: 33 V _{pp}	
Serial resistance		13 Ohm ±10 %	
Pulse power		600 W / 1 ms	

3. ORDER CODE

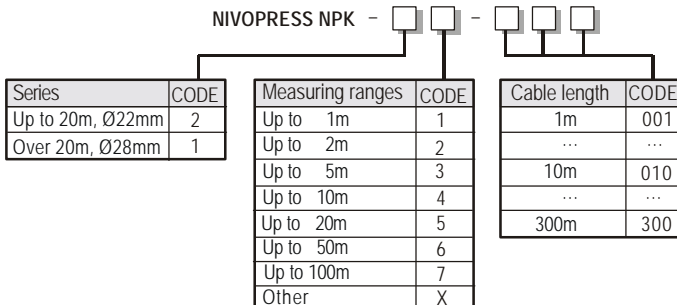

4. TECHNICAL DESCRIPTION

The two-wire level transmitter consists of a special cable containing a capillary pipe and a stress-resistant inlet and of a probe. The probe is a stainless steel cartridge with a membrane at the bottom that is protected by a reinforced plastic covering cap with bore-holes. The level metering is based on the measuring of the pressure difference between the hydrostatic pressure of the liquid column above the probe (prevailing in and outside of the covering cap) and the actual atmospheric pressure (prevailing in the sensor chamber being interlinked through a capillary pipe with the atmosphere). This pressure difference is converted into a 4 to 20 mA output signal by the ceramic transducer (attached to the stainless steel membrane) and the electronics.

5. INSTALLATION

The probe has to be let down to the lowest possible point, for only the height of the column above the probe will be measured. Make sure that the covering of the cable remains intact in the course of lowering the probe. Proper care must be taken with fixing the cable end so that the capillary pipe is not crushed. It is suggested to wind the cable 3-4 times on a pipe having a diameter of 50 to 100 mm and to fix the outrunning cables by a strap. The end of the capillary pipe should be arranged in accordance with that on Diagram 1. in order to ensure that as less humidity can enter the "breathing pipe" as possible.

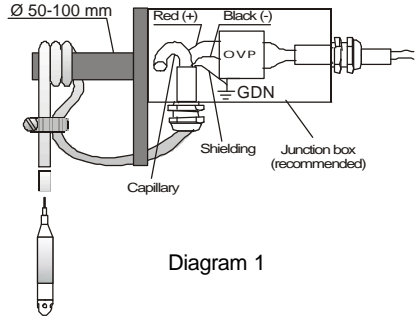

Diagram 1

The cable of the mounted probe must not be cut short!

Over voltage protection is recommended for outdoor applications.

The GND of the OVP must be connected with the shortest possible wire (and without direction changes) to the protecting ground. For distances over 15 to 20 m with cabling in open air between transmitter and processing unit the use of an additional over voltage protection is suggested to protect the processing unit against over voltage. For protection against surges coming through the medium, a protecting electrode e.g. a steel pipe is recommended.

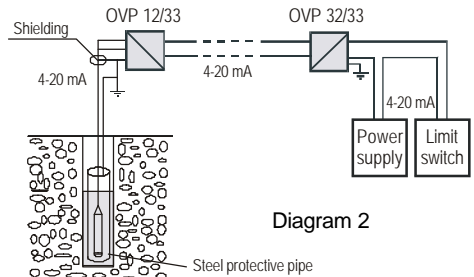

Diagram 2

6. WIRING

The wiring of the probe and of the over voltage protection should be arranged in accordance with Diagram 3 and Diagram 4 respectively.

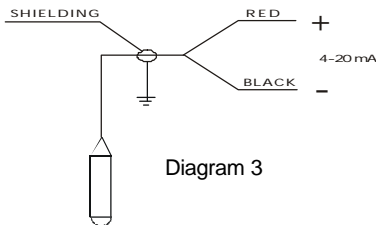

Diagram 3

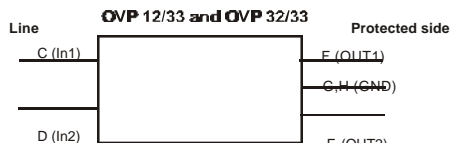
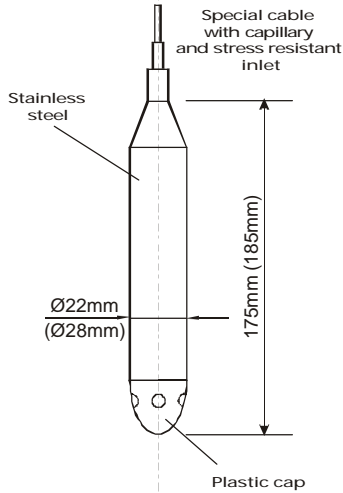

Diagram 4

The line where over voltage may occur should be connected to the terminal IN and the transmitter (or process unit) to be protected to the terminal OUT.

7. DIMENSIONS



8. MAINTENANCE, REPAIR

The device does not require routine maintenance. In some instances, however, the probe may need occasional cleaning to remove surface deposits. Avoid cleaning with abrasive tools.

9. STORAGE CONDITIONS

Environment temperature: +14 to +140 °F (-10 to +60 °C)

10. PERFORMANCE GUARANTEE

Since 1986, every instrument sold by **HiTECH** has been guaranteed to perform in the application it originally was engineered and recommended for. Our company policy remains the same, every product sold comes with a **written performance guarantee**.

Should the equipment be unable to perform satisfactorily in your application and we are not able to correct the problem, we will accept the instrument in return and issue full credit.

This performance guarantee is valid for 60 days. Thereafter, our standard limited two years factory warranty goes into effect.

HiTECH Technologies, Inc.

301 Oxford Valley Road - Building 505A - Yardley, PA 19067-7706

Tel: 215. 321. 6012; Fax: 215. 321. 6067

Tech Support (Toll Free) 866-DrLevel or 888-NIVELCO

Email: info@DrLevel.com or info@hitechtech.com

Web Site: www.DrLevel.com or www.hitechtech.com