

SonicLaser™ Sensing Technology

IDEAL for:

- ◆ Breweries
- ◆ Chemicals
- ◆ Food Processing
- ◆ Pharmaceuticals
- ◆ Power Plants
- ◆ Pulp & Paper
- ◆ Water & Wastewater



ADVANTAGES

- Narrow Beam Angle ($\pm 2.5^\circ$ from center axis)
- Built-in temperature compensation
- Simple intuitive programming
- Fixed target suppression
- 32-point linearization
- 4 to 20 mA output

HART protocol w/PC software (optional)

- Operating modes:

Basic: Simple start up and 4/20 mA programming without Display Module option.

Sophisticated: Using the Display Module (SAP-200) which includes a 6 digit custom LCD display, the operator can choose between a menu driven QUICKSET or full parameter programming.

The SE/SG-37 EchoTREK™ is HiTECH's new TWO-WIRE Loop-Powered SMART ultrasonic level transmitters using unique SonicLaser™ technology.

The Two-Wire EchoTREK™ combined with the optional Solar Power Package is the ideal solution for applications in remote locations.

EchoTREK™ compact transmitters include the latest version of the field proven QUEST II™ advanced, process adaptive signal processing software to identify and validate the surface signal.

HiTECH's SonicLaser™, utilizing unique patented technology, is the best ultrasonic level measurement system on the market today. Presently there are more than 20,000 narrow beam SonicLaser™ sensors, operating successfully worldwide, in various harsh industrial processing environments.



HiTECH

Technologies, Inc.

EchoTREK™
THE NEXT GENERATION

SMART

TWO-WIRE LEVEL TRANSMITTER

Model SE/SG-37

SPECIFICATIONS

Model xxx- 37	Range 14" to 26 feet (0.35 to 8 meters)	Power supply / Consumption 11.4 ...36 VDC / 48 mW ...720 mW Electrically isolated and surge/transient protected Optional Solar Power Package
Accuracy *	± (0.2% of the measured distance plus 0.05% of the range)	Materials Transducer: Polypropylene (PP) or Kynar (PVDF) Housing: Plastic (PBT fibreglass reinforced) or Aluminium (Powder paint coated)
Resolution (Dependent upon measured distance) < 80 inches: 0.04 inches 80...198 inches: 0.08 inches 16.4...26 feet: 0.2 inches		Temperature Process: -22 °F ...+194 °F Ambient: -22 °F ...+140 °F w/SAP-200: -13 °F ...+140 °F
Outputs:: 4 ...20 mA, Rmax 600 Ohm HART protocol w/PC software (optional)		Pressure (Absolute) 0.5** ... 3 bar (0.05 ... 0.3 MPa)
Loop power test connectors: Ammeter plug-in, 200 mV, 0.5%		Seals PP transducer: EPDM PVDF transducer: FPM (Viton)
Display: 6 digits, icons & bargraph, (SAP-200 module)		Rating Sensor: NEMA 4X & 6 Housing: NEMA 6

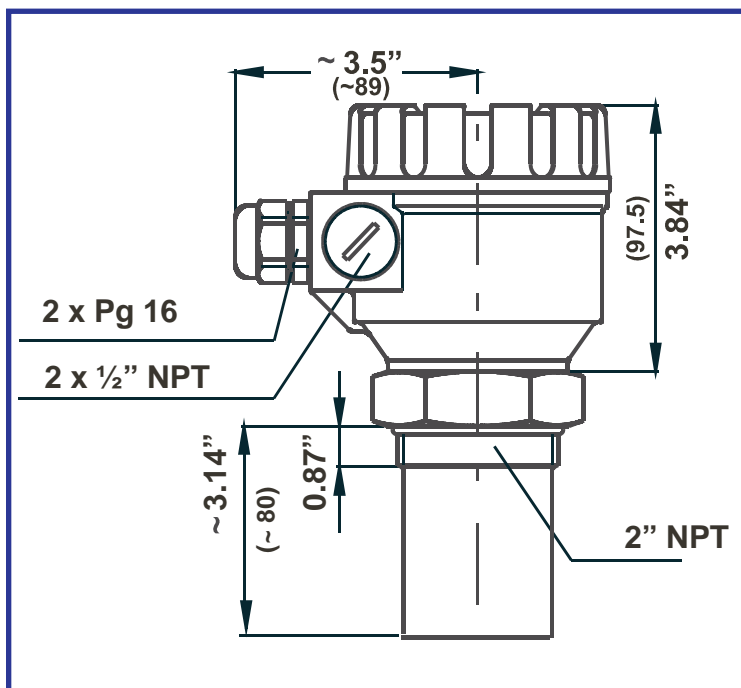

PERFORMANCE GUARANTEE

Since 1986, every instrument sold by *HiTECH* has been guaranteed to perform in the application it originally was engineered and recommended for. Our company policy remains the same, every product sold comes with a **written performance guarantee.**

Should the equipment be unable to perform satisfactorily in your application and we are not able to correct the problem, we will accept the instrument in return and issue full credit.

This performance guarantee is valid for 60 days. Thereafter, our standard limited two years factory warranty goes into effect.

Copyright HiTECH Technologies, Inc. 2003 -2004



HiTECH Technologies, Inc.

301 Oxford Valley Road, Yardley, PA 19067-7706

Technical support: 800. 755. 4507

Tel: 215. 321. 6012 Fax: 215. 321. 6067 - www.hitechtech.com